



HSM9 & HSM12

PARTS BOOK



Revision #02

HSM9 Starting Serial #411626

HSM12 Starting Serial #411215

HSMFG0414

Part #63380

Manufactured By

H&S MANUFACTURING CO.,INC.

P.O. BOX 768 (715) 387-3414 FAX (715) 384-5463

MARSHFIELD, WISCONSIN 54449

CONTENTS

Instructions for Ordering Parts.	1
Figure 1 - 9'/12' Main Frame.	2-5
Figure 2 - Pole.	6-7
Figure 3 - 9' Pick - Up Head.	8-11
Figure 4 - 12' Pick - Up Head.	12-15
Figure 5 - 9' Merger Hydraulics.	16-17
Figure 6 - 12' Merger Motor Circuit.	18-19
Figure 7 - 12' Merger/Head Lift Hydraulics.	20-21
Figure 8 - 9'/12' Merger Extension.	22-23
Figure 9 - 9'/12' Merger 2'/4'/6' Extension	24-25
Figure 10 - 9' Merger Wiring & Lights.	26-27
Figure 11 - 12' Merger Wiring.	28-29
Figure 12 - 9'/12' Merger Control Box.	30-31
Figure 13 - 9'/12' Merger Pickup Hydraulic Cylinder 2 X 8.	32
Figure 14 - 9'/12' Merger Pole Hydraulic Cylinder 16".	33
Figure 15 - 9'/12' Merger Optional Extension Hydraulic Cylinder.	34
Figure 16 - 9'/12' Optional Windrow Inverter.	35
Figure 17 - 9'/12' Merger Optional Cross Conveyor Stop Kit.	36-37
Figure 18 - 9'/12' Merger Optional Wet Kit.	38-41
Figure 19 - Extension Shut-off.	42-43
Parts Notes.	44

INSTRUCTIONS FOR ORDERING PARTS

All service parts should be ordered through your authorized H&S dealer. They will be able to give you faster service if you will provide them with the following

1. Model & Serial number is located on the right side frame behind the transport wheel.
2. All reference to left or right apply to the machine as viewed from the rear.
3. Parts should not be ordered from illustration only. Please order by complete part number.
4. If your dealer has to order parts - give shipping instructions:

VIA truck - large pieces (please specify local truck lines)

VIA United Parcel Service (include full address)

H&S MFG. CO. INC.	
MARSHFIELD, WIS.	
MOD. NO.	<input type="text"/>
SER. NO.	<input type="text"/>
DESCR.	<input type="text"/>

PLEASE RECORD NUMBERS FOR YOUR UNIT FOR QUICK REFERENCE

ABOUT IMPROVEMENTS

H&S IS CONTINUALLY STRIVING TO IMPROVE IT'S PRODUCTS

We must therefore, reserve the right to make improvements or changes whenever it becomes practical to do so without incurring any obligation to make changes or additions to the equipment previously sold.

FIGURE 1
9'/12' MAIN FRAME

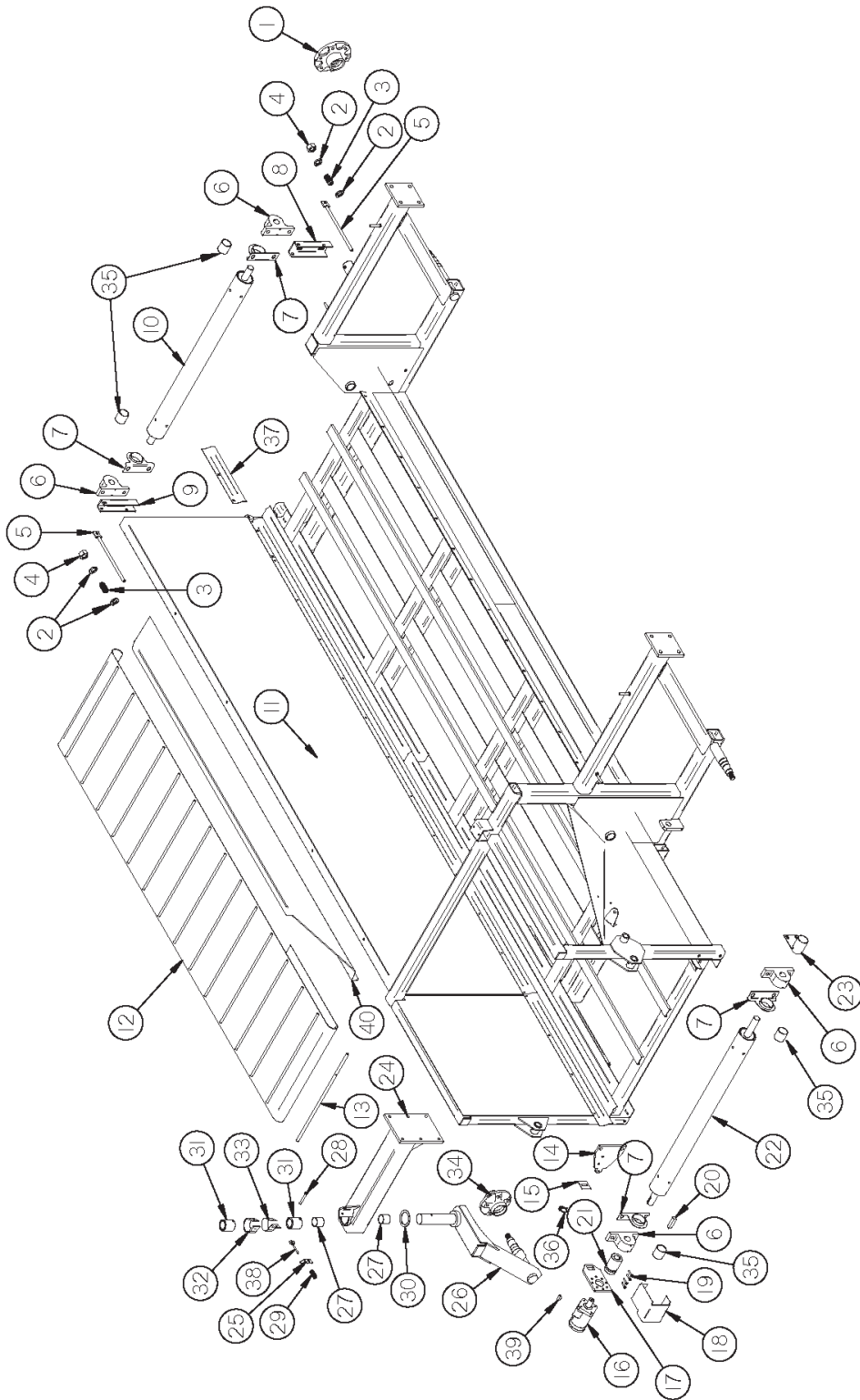

FIGURE 1

9'12' MAIN FRAME

PART #			
ITEM	9' HEAD	12' HEAD	DESCRIPTION
1	RG101	“	HUB- 6 BOLT
*	RG98	“	SEAL
*	12N18	“	INNER BEARING
*	12N19	“	INNER RACE
*	YBSD16010	“	STUD BOLT
*	YNWL16005	“	STUD NUT
*	17G146	“	OUTER RACE
*	17G145	“	OUTER BEARING
*	YWFL28010	“	WASHER
*	YNSL28005	“	HUB NUT
*	17G144	“	HUB CAP
*	YPCT05020	“	5/32" X 1-3/4" COTTER PIN
*	UR1	“	9.5 L X 15 TIRE AND TUBE
*	12N24	“	WHEEL 15 X 8
2	YWFL16005	“	WASHER 1/2"
3	DWM125	“	SPRING-BLUE
4	YNHX16005	“	NUT 1/2"
5	DWM25	“	TIGHTENER
6	DWM132	“	PILLOW BLOCK BEARING
7	DWM36	“	ANTI-WRAP GUARD
8	SWM34	“	TIGHTENER ARM
9	SWM33	“	BACK TIGHTENER ARM
10	SWM10	“	CONVEYOR ROLLER
11	WM229	WM308	MAIN FRAME
12	WM237	WM301	CROSS CONVEYOR BELT
*	SWM38	“	CROSS CONVEYOR LACING
*	WM379	“	DUTCHMEN BELT 42" X 3-1/4" SINGLE
13	SWM37	“	LACING PIN
14	DWM51	“	MALE TORQUE ARM
15	DWM45	“	MOTOR SPACER
16	DF1	“	HYDRAULIC MOTOR
*	WM225	“	SEAL KIT
17	DWM39	“	TORQUE ARM
18	DWM41	“	MOTOR SHIELD
19	YSHS08045		CAP SCREW-COUPLER

NOTE: * MEANS NOT SHOWN

“ MEANS SAME AS PREVIOUS MODEL

FIGURE 1

9'/12' MAIN FRAME

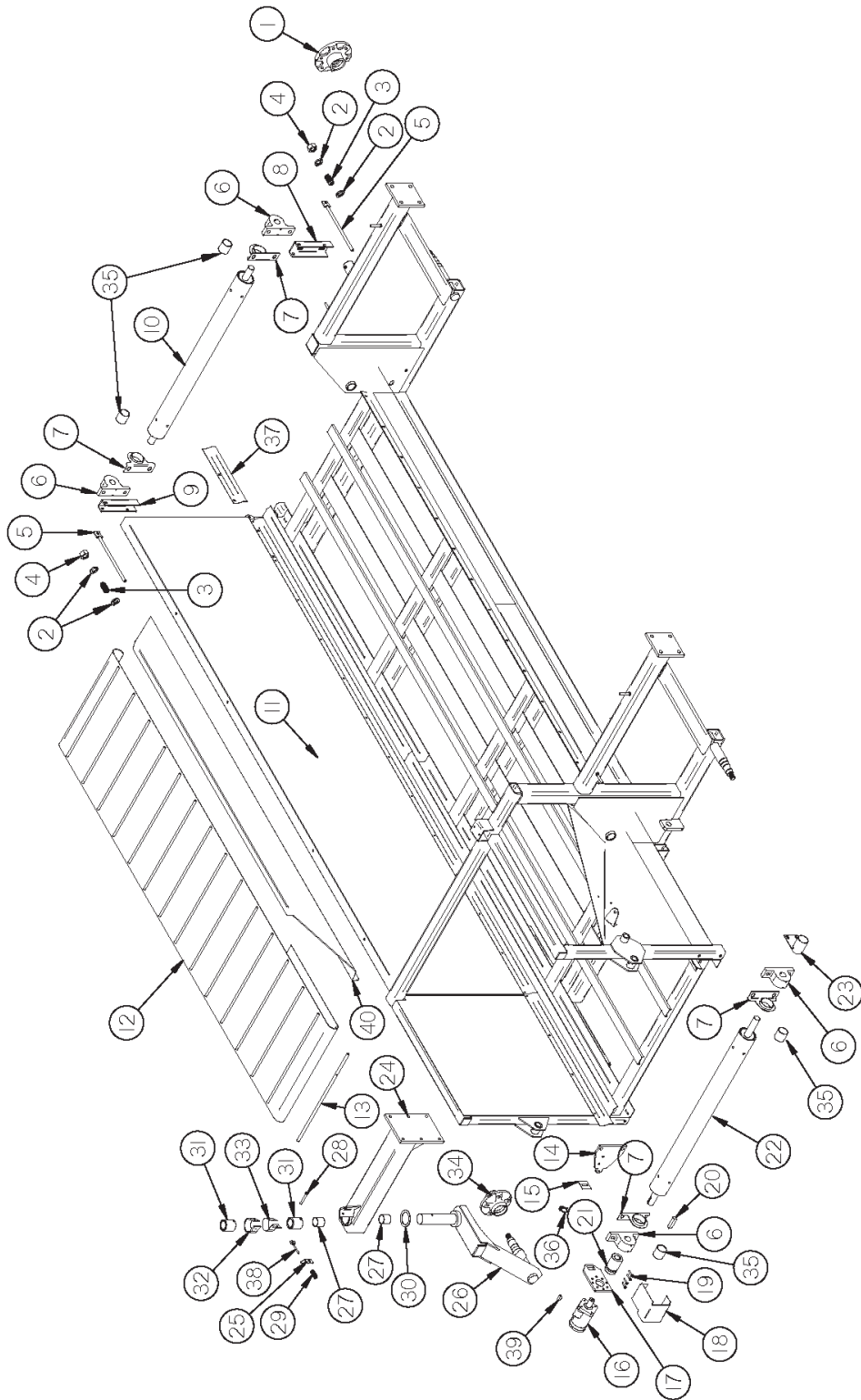

FIGURE 1

9'/12' MAIN FRAME

<u>PART #</u>			
<u>ITEM</u>	<u>9' HEAD</u>	<u>12' HEAD</u>	<u>DESCRIPTION</u>
20	G23B	"	KEY 5/16" X 1-3/8"
21	DWM27	"	COUPLER
22	SWM11	"	DRIVE ROLLER
23	DWM31	-	SHAFT SHIELD
*	-----	WM309	SHAFT SHIELD
24	SWM3	"	CASTER MOUNT
25	WM211	"	BRAKE ANGLE
26	SWM2	"	CASTER
27	RG26	"	BUSHING, BRONZE, 2.015" ID X 2.25" OD X 2.00"
28	BFR313	"	ROLL PIN 5/16" X 2-3/4"
29	WM210	"	SPRING-RED
30	RG24	"	BRONZE WASHER 2"ID X 3"OD X 1/8"
31	DWM59	"	BRAKE BUSHING
32	WM288	"	BRAKE PAD
33	WM286	"	BRAKE BAND
34	BFR75	"	HUB (COMPLETE)
*	BFR57	"	SEAL
*	17G145	"	INNER BEARING
*	17G146	"	INNER RACE
*	YBSD16005	"	STUD BOLT
*	YNWL16005	"	STUD NUT
*	BFR61	"	OUTER RACE
*	BFR62	"	OUTER BEARING
*	YWFL24010	"	WASHER
*	YNSL24010	"	NUT
*	BFR66	"	HUB CAP
*	YPCT05010	"	COTTER PIN
*	BFR128	"	TIRE 6.70 X 15 SL
*	BFR67	"	WHEEL 15 X 5
35	SWM30	"	SPACER
36	S122	"	CLIP PIN CABLE
37	SWM59	"	LEFT REAR GUARD EXTENSION
38	YBTE10040	"	I-BOLT
39	5B10	"	KEY 1/4" X 1" WOODRUFF
40	WM300	"	HAY DEFLECTOR

NOTE: * MEANS NOT SHOWN
“ MEANS SAME AS PREVIOUS MODEL
---- MEANS NOT USED ON THIS MODEL

FIGURE 2

POLE

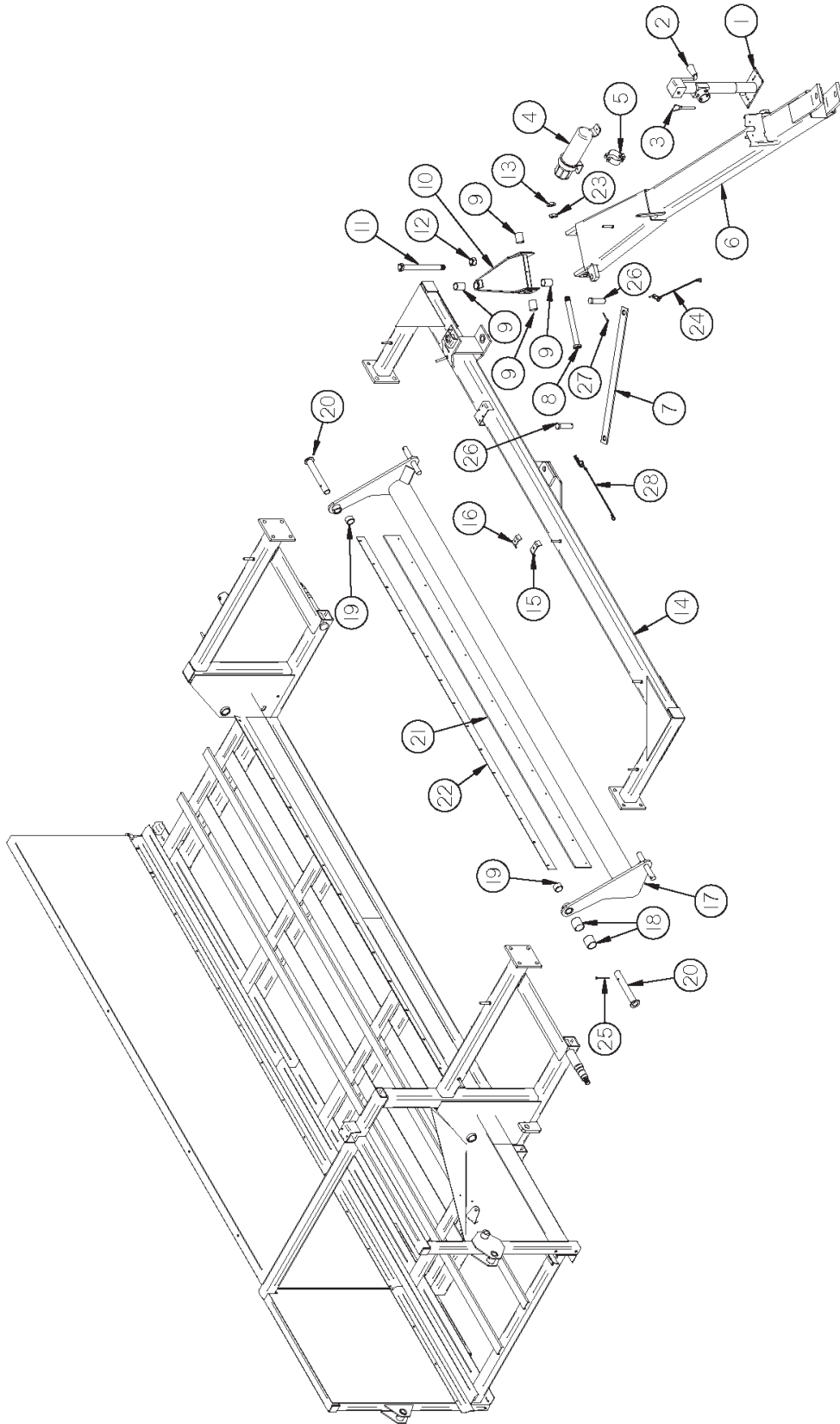

FIGURE 2

POLE

<u>ITEM</u>	<u>9' HEAD</u>	<u>12' HEAD</u>	<u>DESCRIPTION</u>
1	BFR753	"	JACK
2	5N78	"	JACK HANDLE
3	12N117	"	JACK PIN & CHAIN
4	S522	"	MANUAL HOLDER
5	S523	"	MANUAL CLAMP LARGE
6	WM227	"	POLE
7	WM129	"	TRANSPORT LOCK
8	WM202	"	POLE PIN
9	RG11	"	BUSHING 1" ID X 1-1/4" OD X 2"
10	WM228	"	STEERING PIVOT
11	WM231	"	QUEEN PIN
12	YNSL32005	"	NUT-SLOTTED 1"-14 FULL THREAD
13	YNJM32005	"	JAM NUT 1"-14 FULL THREAD
14	WM226	WM305	TONGUE CROSS
15	HE42	"	HOSE BRACKET
16	23N67	"	HOSE BRACKET FRONT
17	WM230	WM306	PICKUP LIFTER
18	RG132	"	BUSHING 1-1/4" ID X 2"
19	SWM30	"	SPACER
20	SWM13	"	PIN
21	WM235	WM304	SKIRT BELT
22	WM236	WM302	SKIRT
23	YWSI32005	"	1" STAR WASHER
24	WM378	"	LANYARD, TRANSPORT LOCK
25	YBHH08085	"	BOLT 1/4" X 3" GR. 5
26	YPCV32020	"	CLEVIS PIN 1" X 3-1/4"
27	YPCT06020	"	COTTER PIN
28	WM377	"	LANYARD, CROP ROLLER

NOTE: " MEANS SAME AS PREVIOUS

FIGURE 3

9' PICK - UP HEAD

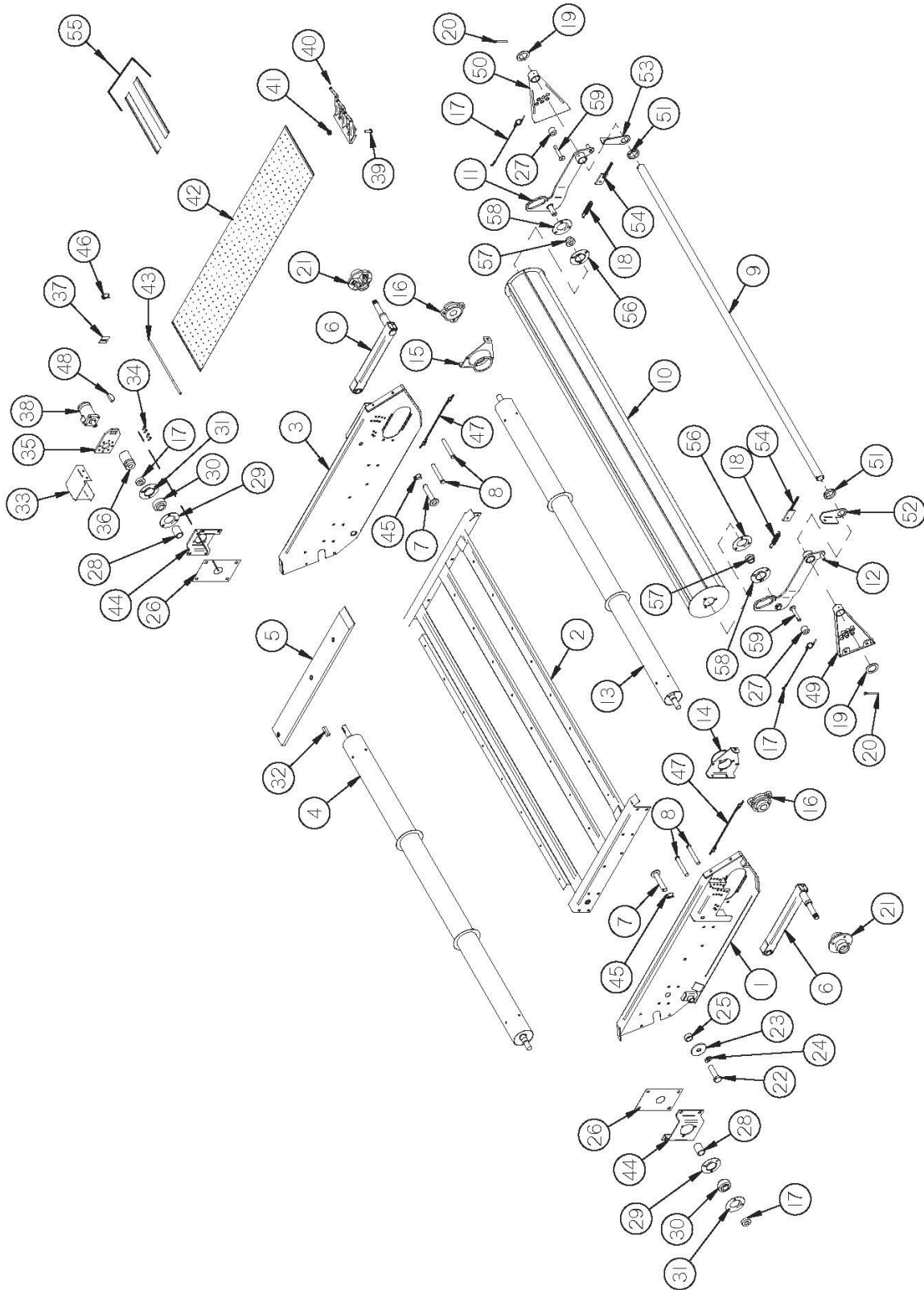

FIGURE 3

9' PICK - UP HEAD

<u>ITEM</u>	<u>PART #</u>	<u>DESCRIPTION</u>
1	DWM6	RIGHT HEAD PANEL
2	WM234	FLAT BELT FRAME
3	DWM5	LEFT HEAD PANEL
4	WM341	HEAD DRIVE ROLLER
5	SWM15	SLIDES (8)
6	DWM229	GAUGE ARMS
7	DWM7	PIVOT PIN
8	YPCV16020	CLEVIS PIN 1/2" X 5"
9	WM357	FRONT SUPPORT
10	WM356	9' CROP ROLLER
11	WM348	LEFT ARM
12	WM349	RIGHT ARM
13	WM342	FRONT IDLER ROLLER
14	WM179	RIGHT FRONT ROLLER BRACKET
15	WM192	LEFT FRONT ROLLER BRACKET
16	55660	3 BOLT PILLOW BLOCK BRG W/COLLAR
17	WM377	LANYARD, CROP ROLLER
18	ST36	SPRING
19	DWM227	WIND GUARD WASHER
20	YPCT08010	COTTER PIN 1/4" X 2-1/2"
21	CAT177	HUB-COMPLETE
*	CAT135A	SEAL
*	CAT10	BEARING (2)
*	BFR275	RACE (2)
*	YBSD16005	STUD
*	YNWL16005	LUG NUT
*	YNSL32005	HEX NUT SLOTTED 1"-14
*	YPCT05010	COTTER PIN
*	CAT46	HUB CAP
*	SWM17	WHEEL (2)
*	SWM18	TIRE 5.70-8 (2)
22	YBHH32005	BOLT 1" X 2-1/2" GR.5 FULL THREAD
23	WM218	WASHER
24	YWLO32005	1" LOCK WASHER
25	WM183	PIVOT BUSHING
26	WM180	SIDE PANEL SLOT PLATE
27	WM187	BEARING BRACKET RH
28	WM343	SPACER

NOTE: * MEANS NOT SHOWN

FIGURE 3

9' PICK - UP HEAD

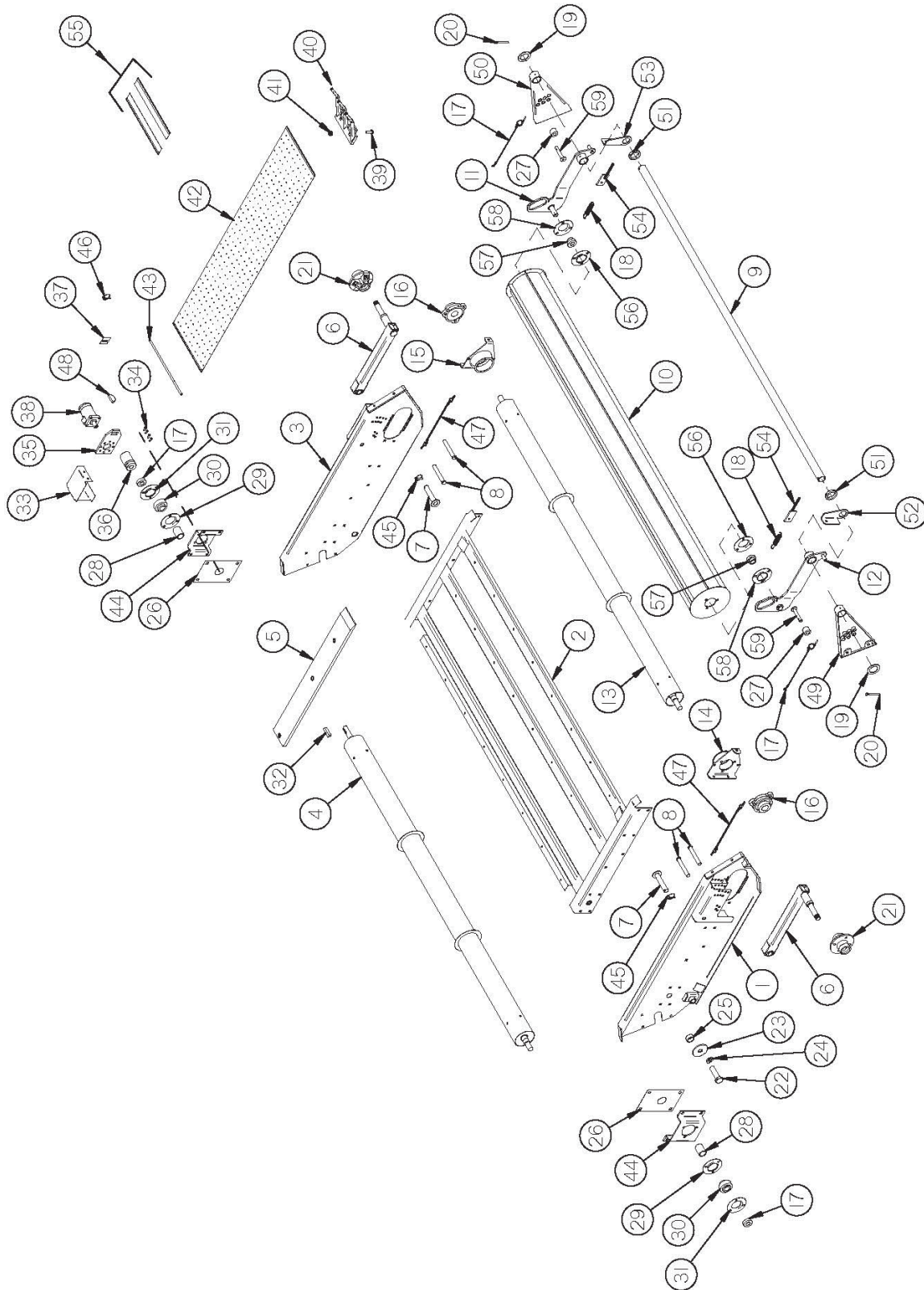

FIGURE 3

9' PICK - UP HEAD

<u>ITEM</u>	<u>PART #</u>	<u>DESCRIPTION</u>
29	F145	FLANGE
30	55659	1-1/4" HEAVY BRG WITH LOCK COLLAR
31	F143	FLANGE (GREASEABLE)
32	G23B	KEY 5/16" X 1-3/8"
33	DWM40	HEAD SHIELD
34	YSHS08045	CAP SCREW-COUPLER
35	DWM39	HYDRAULIC MOTOR MOUNT
36	DWM27	COUPLER
37	DWM45	MOTOR SPACER
38	DWM84	HYDRAULIC MOTOR
*	WM225	SEAL KIT
39	YBEV08005	1/4" X 3/4" ELEVATOR BOLTS (780)
40	SWM1	PICKUP TEETH (390)
41	YNLK08005	1/4" KEPS LOCK NUTS (780)
42	SWM56	PICKUP BELTS - ONLY
*	SWM57	COMPLETE BELT W/ TEETH
43	SWM41	LACING PIN
44	WM186	BEARING BRACKET LH
45	YPCT06020	3/16" X 2" COTTER PIN
46	YPLY08011	LYNCH PIN, 1/4" X 1-9/16" #63-02
47	HD225	LANYARD, HITCH
48	5B10	KEY 1/4" X 1" WOODRUFF
49	WM350	RIGHT BRACKET
50	WM351	LEFT BRACKET
51	WM347	COLLAR
*	YPSKP10010	SET SCREW, SOCKET, 5/16 - 18 X 3/8
52	WM362	SPRING TIGHTENER BRACKET RIGHT
53	WM363	SPRING TIGHTENER BRACKET LEFT
54	12V78	TIGHTENER BRACKET
55	SWM64	REPAIR DUTCHMAN KIT
*	SWM63	DUTCHMAN ASSEMBLY
56	F14	FLANGE
57	12N122	1-1/4" BEARING WITH LOCK COLLAR
58	F114A	FLANGE (45° ZERK)
59	WM354	ADJUSTMENT PIN

NOTE: * MEANS NOT SHOWN

FIGURE 4

12' PICK - UP HEAD

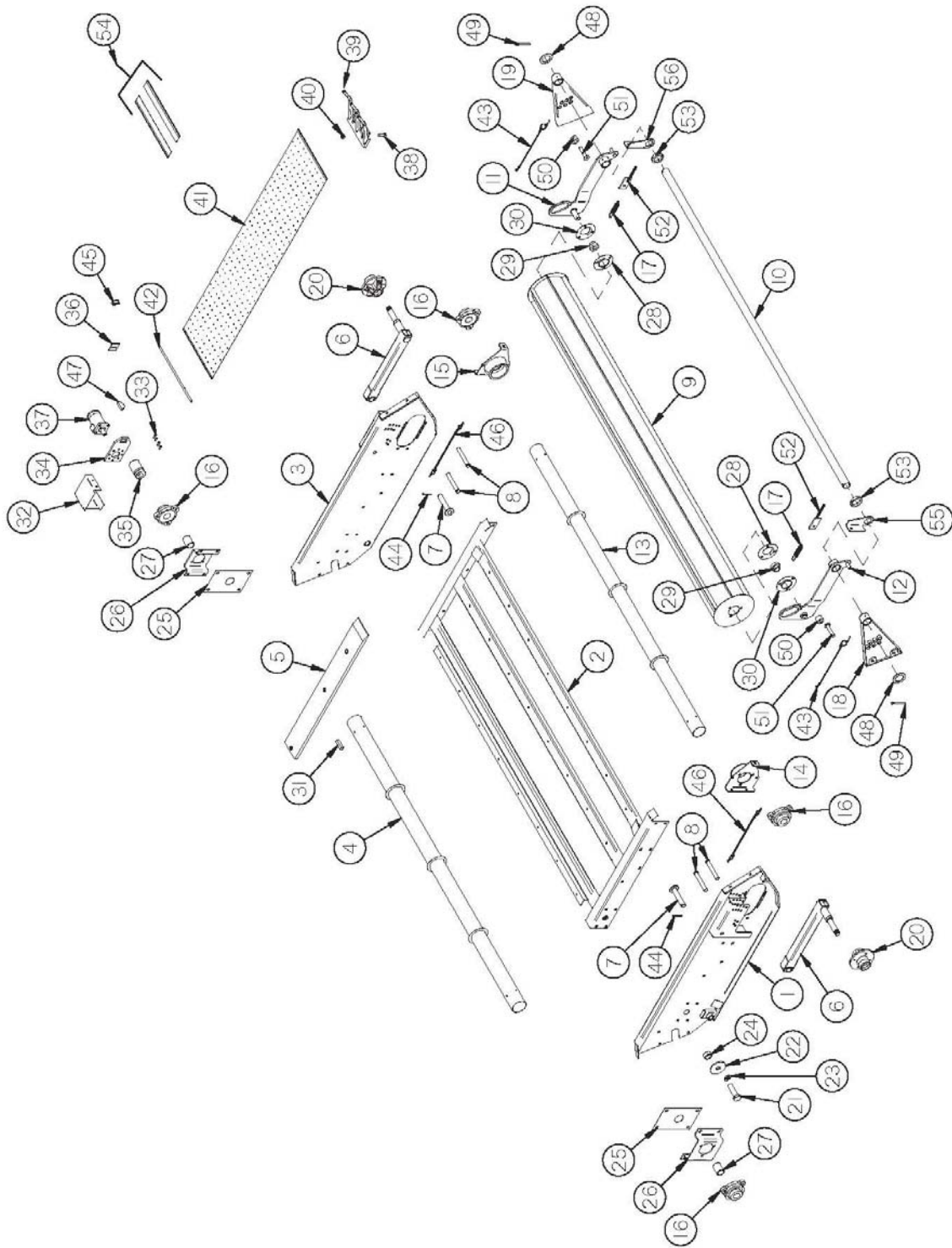

FIGURE 4

12' PICK - UP HEAD

<u>ITEM</u>	<u>PART #</u>	<u>DESCRIPTION</u>
1	DWM6	RIGHT HEAD PANEL
2	WM307	FLAT BELT FRAME
3	DWM5	LEFT HEAD PANEL
4	SHM22	HEAD DRIVE ROLLER
5	SWM15	SLIDES (8)
6	DWM229	GAUGE ARMS
7	DWM7	PIVOT PIN
8	YPCV16020	CLEVIS PIN 1/2" X 5"
9	WM352	12' CROP ROLLER
10	WM346	FRONT SUPPORT
11	WM348	LEFT ARM
12	WM349	RIGHT ARM
13	SHM21	FRONT IDLER ROLLER
14	WM179	RIGHT FRONT ROLLER BRACKET
15	WM192	LEFT FRONT ROLLER BRACKET
16	55660	3 BOLT PILLOW BLOCK BRG WITH LOCK COLLAR
17	ST36	SPRING
18	WM350	RIGHT BRACKET
19	WM351	LEFT BRACKET
20	CAT177	HUB-COMPLETE
*	CAT135A	SEAL
*	CAT10	BEARING (2)
*	BFR275	RACE (2)
*	YBSD16005	STUD
*	YNWL16005	WHEEL NUT, 1/2" - 20 UNF
*	YNL32006	HEX NUT, SLOTTED JAM, 1"-14
*	YPCT05010	COTTER PIN
*	CAT46	HUB CAP
*	SWM17	WHEEL (2)
*	SWM18	TIRE 5.70-8 (2)
21	YBHH32005	BOLT 1" X 2-1/2" GR.5 FULL THREAD
22	WM218	WASHER
23	YWLO32005	1" LOCK WASHER
24	WM183	PIVOT BUSHING
25	WM180	SIDE PANEL SLOT PLATE

NOTE: * MEANS NOT SHOWN

FIGURE 4

12' PICK - UP HEAD

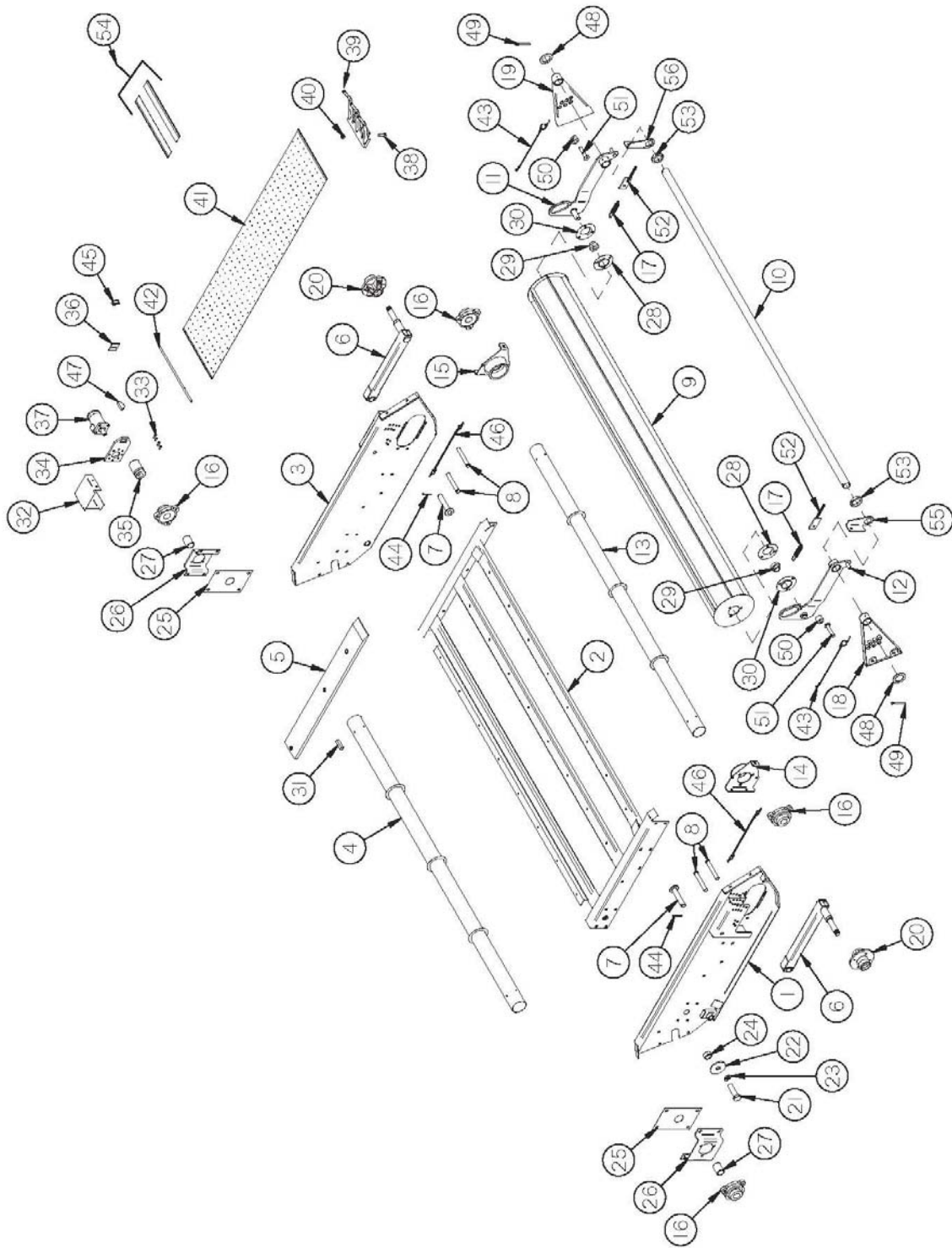

FIGURE 4

12' PICK - UP HEAD

<u>ITEM</u>	<u>PART #</u>	<u>DESCRIPTION</u>
26	SHM13	BEARING BRACKET RH
27	SHM23	SPACER
28	F14	FLANGE
29	12N122	1-1/4" BEARING WITH LOCK COLLAR
30	F114A	FLANGE (45° ZERK)
31	G23B	KEY 5/16" X 1-3/8"
32	DWM40	HEAD SHIELD
33	YSHS08045	CAP SCREW-COUPLER
34	DWM39	HYDRAULIC MOTOR MOUNT
35	DWM27	COUPLER
36	DWM45	MOTOR SPACER
37	DWM84	HYDRAULIC MOTOR
*	WM225	SEAL KIT
38	YBEV08005	1/4" X 3/4" ELEVATOR BOLTS (780)
39	SWM1	PICKUP TEETH (390)
40	YNLK08005	1/4" KEPS LOCK NUTS (780)
41	SWM56	PICKUP BELTS - ONLY
*	SWM57	COMPLETE BELT W/ TEETH
42	SWM41	LACING PIN
43	SHM12	BEARING BRACKET LH
44	YPCT06020	3/16" X 2" COTTER PIN
45	YPLY08010	LYNCH PIN, 1/4" X 1-1/2"
46	HD225	LANYARD, HITCH
47	5B10	KEY 1/4" X 1" WOODRUFF
48	DWM227	WIND GUARD WASHER
49	YPCT08010	COTTER PIN 1/4" X 2-1/2"
50	WM353	POLY BUMPER
51	WM354	ADJUSTMENT PIN
52	12V78	TIGHTENER BRACKET
53	WM347	COLLAR
54	SWM64	REPAIR DUTCHMAN KIT
*	SWM63	DUTCHMAN ASSEMBLY
55	WM362	SPRING TIGHTENER BRACKET RIGHT
56	WM363	SPRING TIGHTENER BRACKET LEFT
57	WM377	LANYARD, CROP ROLLER

NOTE: * MEANS NOT SHOWN

FIGURE 5
9' MERGER HYDRAULICS

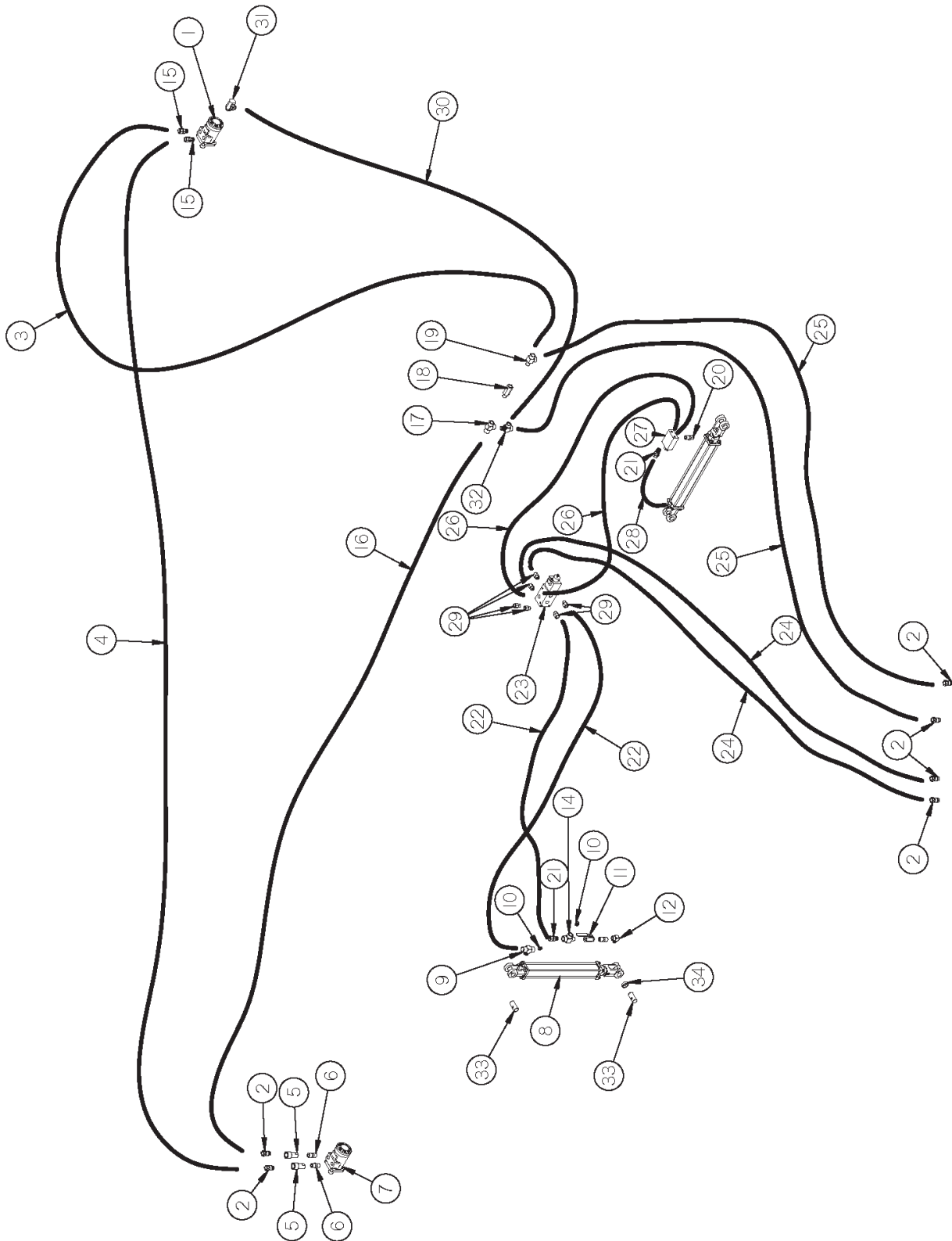

FIGURE 5

9' MERGER HYDRAULICS

<u>ITEM</u>	<u>PART #</u>	<u>DESCRIPTION</u>
1	DWM84	HYDRAULIC MOTOR
*	WM225	SEAL KIT
2	DWM205	MALE COUPLER
3	WM255	HOSE 1/2" X 84"
4	WM310	HOSE 1/2" X 358"
5	DWM206	FEMALE COUPLER
6	WM141	1/2" NIPPLE NUT
7	DF1	HYDRAULIC MOTOR
*	WM225	SEAL KIT
8	55999	2" X 8" HYDRAULIC CYLINDER
9	WM146	1/2" MALE/ FEMALE TEE
10	WM147	PIPE PLUG 3/8"
11	16SV338	3/8" BALL VALVE
12	23N234	ELBOW, STREET, 3/8", 90 DEGREE
13	12V116A	2" X 16" CYLINDER
14	23N116	3/8" SERVICE TEE
15	MA12	1/2" MALE ADAPTER UNION
16	WM311	HOSE 1/2" X 266"
17	DF8	1/2" TEE
18	DF18	1/2" CHECK VALVE
19	16SV352	1/2" SERVICE TEE
20	BFR188	3/8" NIPPLE NUT
21	T244	ADAPTER UNION W/ .042" ORIFICE
*	BFR122	ADAPTER UNION
*	DWM250	ORIFICE .042
22	WM257	HOSE 1/4" X 140"
23	FR81	VALVE
*	WM325	SOLENOID
24	WM258	HOSE 1/4" X 164"
25	WM259	HOSE 1/2" X 164"
26	WM260	HOSE 1/4" X 24"
27	WM176	POLE LOCK VALVE
28	BFR315	HOSE 1/4" X 20"
29	WM148	FEMALE ADAPTERS
30	WM271	HOSE 1/4" X 102"
31	DWM119	O-RING ADAPTER
32	LW96	TEE
33	BFR517	CYLINDER PIN
34	K132	CYLINDER SPACER

NOTE: * MEANS NOT SHOWN

FIGURE 6
12' HEAD MERGER/MOTOR CIRCUIT

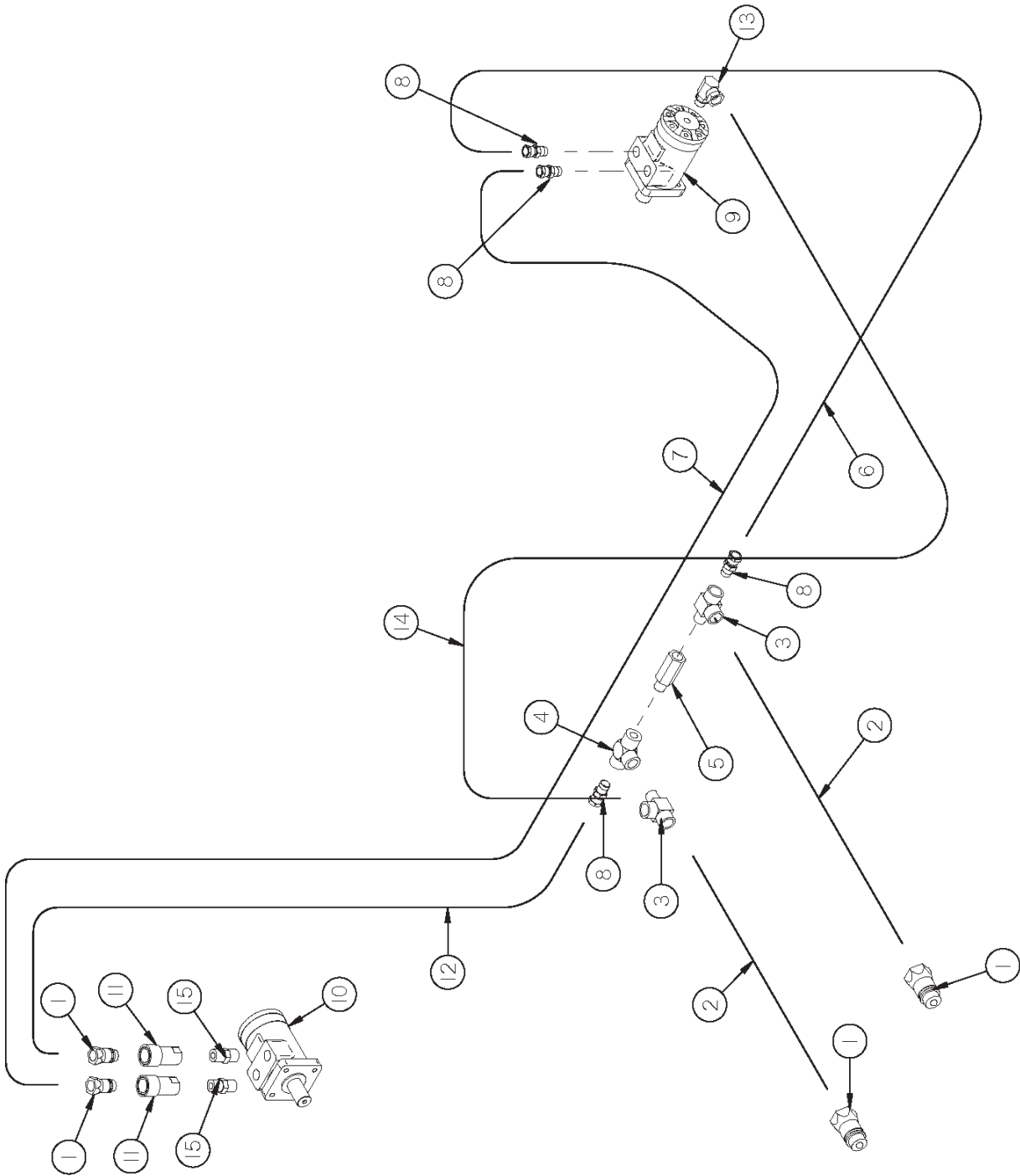

FIGURE 6

12' HEAD MERGER/MOTOR CIRCUIT

<u>ITEM</u>	<u>PART #</u>	<u>DESCRIPTION</u>
1	DWM205	MALE COUPLER
2	WM259	HOSE 1/2" X 164"
3	16SV352	1/2" SERVICE TEE
4	DF8	1/2" TEE
5	DF18	1/2" CHECK VALVE
6	WM255	HOSE 1/2" X 84"
7	WM312	HOSE 1/2" X 394"
8	MA12	1/2" MALE ADAPTER UNION
9	DWM84	HYDRAULIC MOTOR
*	WM225	SEAL KIT
10	DF1	HYDRAULIC MOTOR
11	DWM206	FEMALE COUPLER
12	WM313	HOSE 1/2" X 302"
13	DWM119	O-RING ADAPTER
14	WM271	HOSE 1/4" X 102"
15	WM141	1/2" NIPPLE NUT

NOTE: * MEANS NOT SHOWN

FIGURE 7

12' MERGER/HEAD LIFT HYDRAULICS

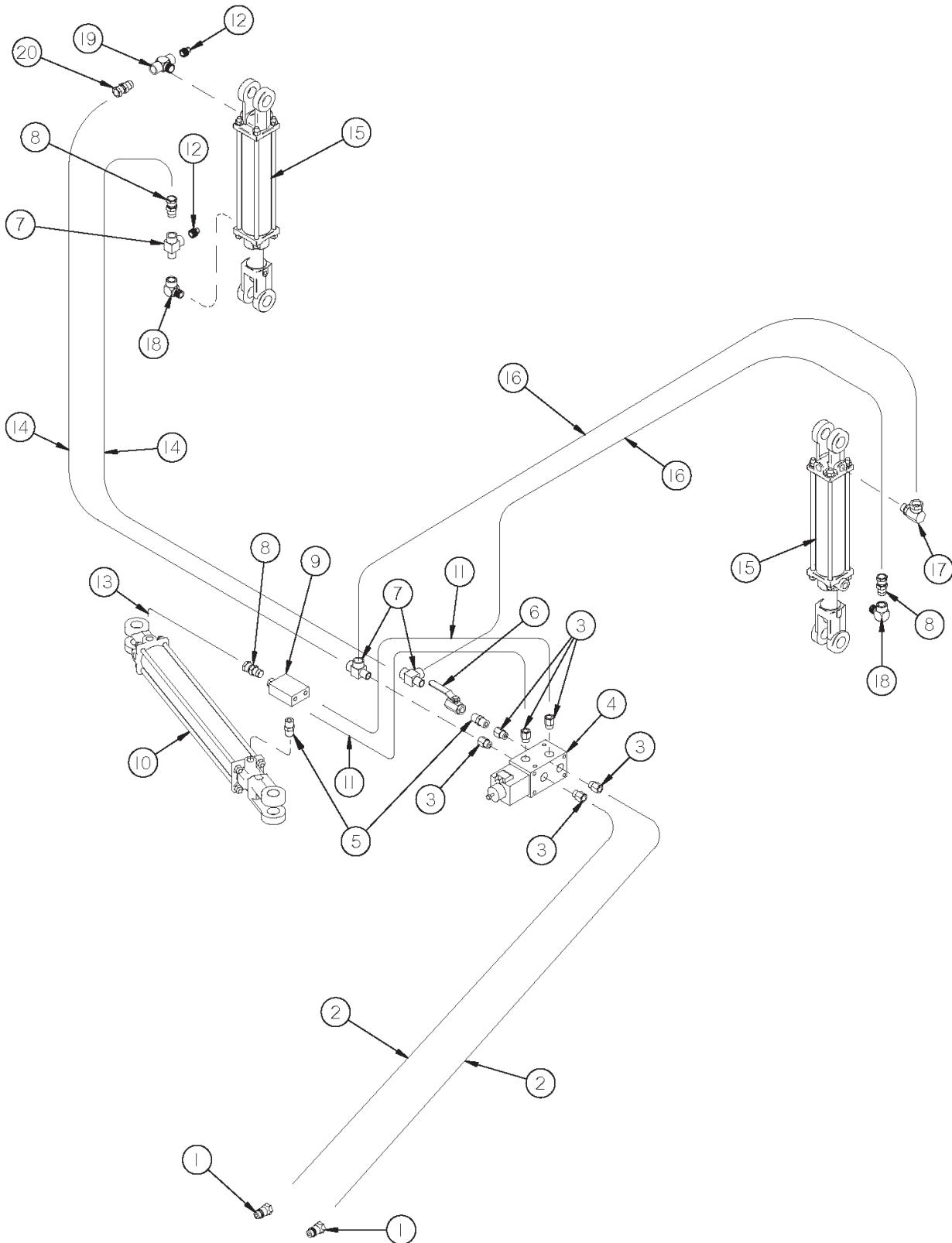

FIGURE 7

12' MERGER/HEAD LIFT HYDRAULICS

<u>ITEM</u>	<u>PART #</u>	<u>DESCRIPTION</u>
1	DWM205	MALE COUPLER
2	WM258	HOSE 1/4" X 164"
3	WM148	FEMALE ADAPTERS
4	FR81	VALVE
*	WM325	SOLENOID
5	BFR188	3/8" NIPPLE NUT
6	16SV338	3/8" BALL VALVE
7	23N116	3/8" SERVICE TEE
8	T244	ADAPTER UNION W/ .042" ORIFICE
*	BFR122	ADAPTER UNION (THREADED)
*	DWM250	ORIFICE .042
9	WM176	POLE LOCK VALVE
10	12V116A	2" X 16" CYLINDER
11	WM260	HOSE 1/4" X 24"
12	WM147	PIPE PLUG 3/8"
13	BFR315	HOSE 1/4" X 20"
14	WM315	1/4 X 175" - 3/8 MP & 3/8 MP
15	55999	2" X 8" HYDRAULIC CYLINDER
16	WM314	1/4 X 108" - 3/8 MP & 3/8 MP
17	DWM110	3/8" STREET ELBOW W/90 DEGREE SWIVEL
18	23N234	3/8" STREET ELBOW
19	WM146	3/8" MALE/ FEMALE TEE
20	DWM233	3/8" ADAPTER UNION (UN-THREADED)

NOTE: * MEANS NOT SHOWN

FIGURE 8

9'/12' MERGER EXTENSIONS

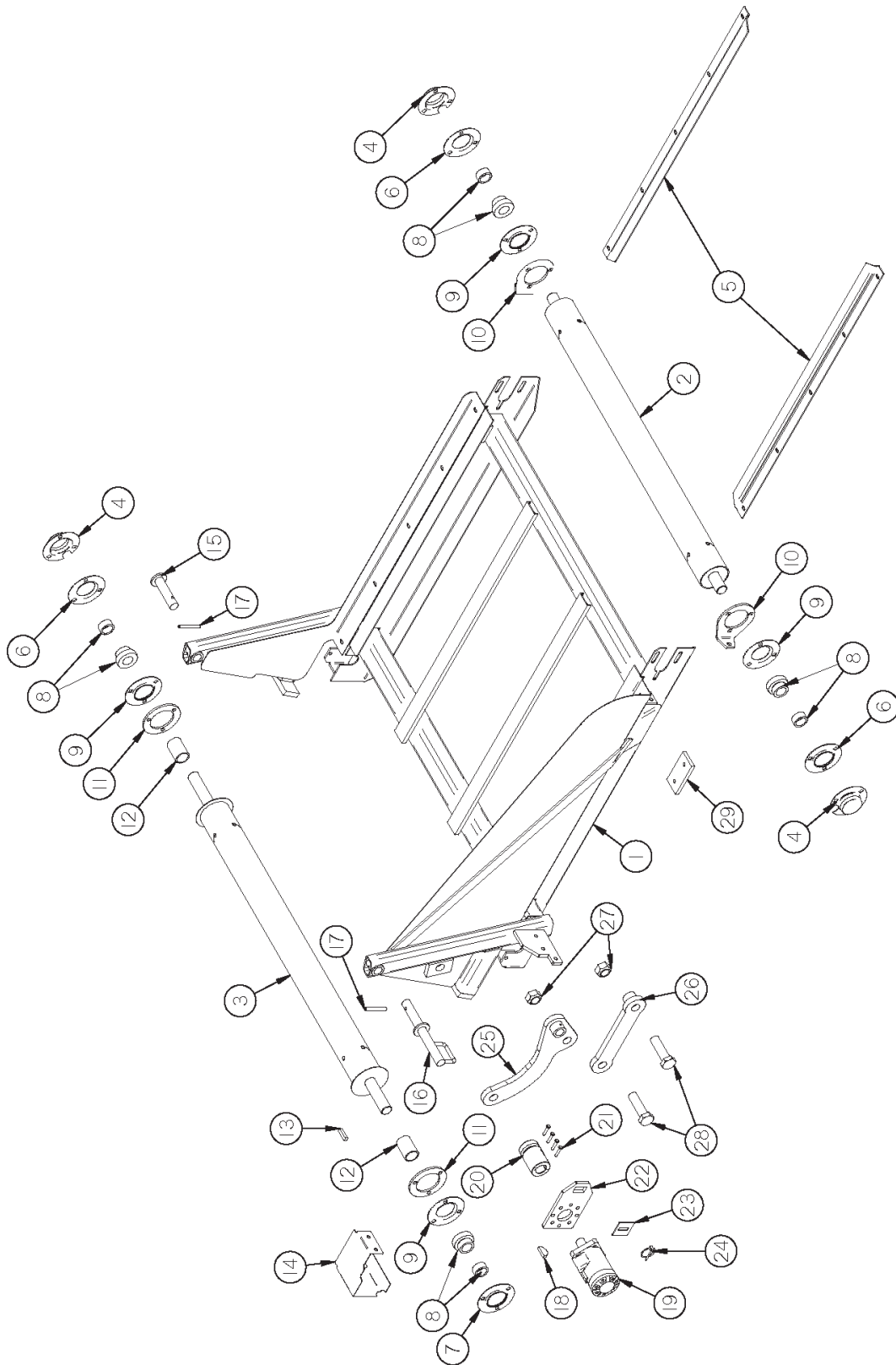

FIGURE 8

9'/12' MERGER EXTENSIONS

<u>ITEM</u>	<u>2' EXT</u>	<u>PART #</u>		<u>DESCRIPTION</u>
		<u>4' EXT</u>	<u>6' EXT</u>	
1	WM316	WM320	WM321	FRAME
2	WM244	"	"	TIGHTENER ROLLER
3	WM243	"	"	DRIVE ROLLER
4	F95	"	"	BEARING SHIELD
5	WM272	WM273	WM274	BELT GUARD
*	WM252	WM253	WM254	BELT
*	SWM37	"	"	LACING PIN
*	SWM38	"	"	LACING- CROSS CONVEYOR
6	F114	"	"	FLANGE W/ STRAIGHT ZERK
7	F114A	"	"	FLANGE W/ 45° ZERK
8	12N122	"	"	BEARING
9	F14	"	"	FLANGE
10	WM250	"	"	FLANGE TIGHTENER
11	23N174	"	"	FLANGE SPACER
12	WM136	"	"	EXT. PVC SHIELD
13	WM121	"	"	SQ. KEY 5/16" X 1"
14	WM319	"	"	MOTOR SHIELD
15	WM245	"	"	EXTENSION PIVOT PIN
16	WM248	"	"	EXTENSION PIVOT PIN FRONT
17	YPEX10015	"	"	EXPANSION PIN, 5/16" X 1-3/4"
18	5B10	"	"	WOODRUFF KEY 1/4" X 1"
19	DF1	"	"	HYDRAULIC MOTOR
*	WM225	"	"	SEAL KIT
20	DWM27	"	"	COUPLER
21	YSHS08045	"	"	SOCKET HEAD CAP SCREW
22	DWM39	"	"	TORQUE ARM
23	DWM45	"	"	MOTOR SPACER
24	YPLY08011	"	"	LYNCH PIN, 1/4 X 1-9/16 #63-02
25	WM317	"	"	LONG LINK
26	WM318	"	"	SHORT LINK
27	YNTL32005	"	"	HEX NUT, TOP LOCK, 1"-8
28	YBHH32010	"	"	BOLT 1" X 3-1/2" GR.5
29	———	WM251	"	RUBBER BUMPER

NOTE: * MEANS NOT SHOWN
—— MEANS NOT USED ON THIS MODEL
" MEANS SAME AS PREVIOUS

FIGURE 9
9'/12' MERGER
2'/4'/6' EXTENSION HYDRAULICS

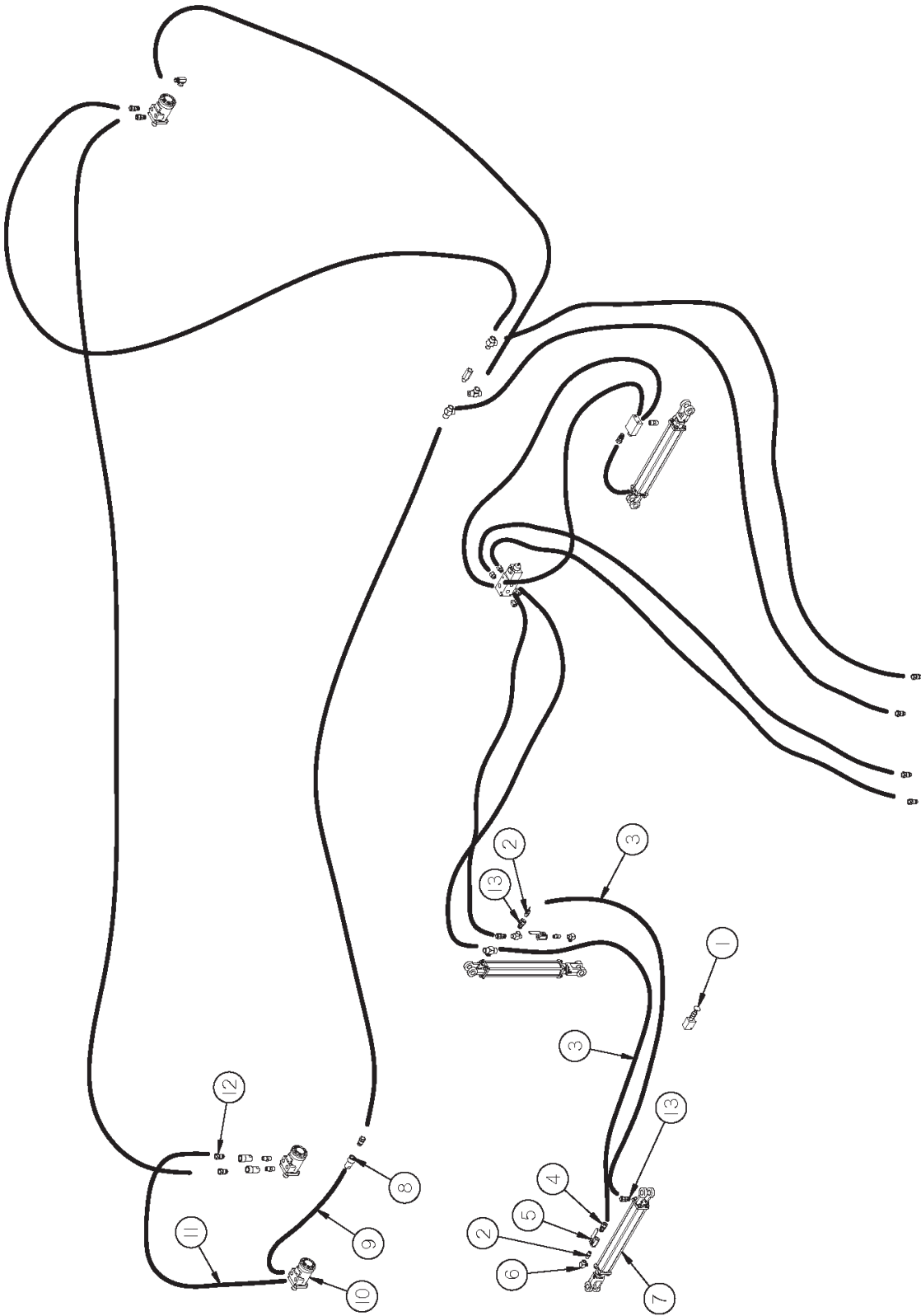

FIGURE 9
9'12' MERGER
2'4'6' EXTENSION HYDRAULICS

<u>ITEM</u>	<u>PART #</u>	<u>DESCRIPTION</u>
1	16SV339	SEQUENCE VALVE
2	BFR188	3/8" NIPPLE NUT
3	WM257	HOSE 1/4" X 140"
4	T244	3/8" UNION ADAPTER W/ .042" ORIFICE
5	16SV338	3/8" BALL VALVE
6	23N234	3/8" STREET TEE
7	56015	2" X 16" HYDRAULIC CYLINDER WITH 90 DEG TO PORTS
8	DWM206	FEMALE COUPLER
9	DWM101	HOSE, 1/2" X 49"
10	DF1	HYDRAULIC MOTOR
*	WM225	SEAL KIT
11	WM264	HOSE 1/2" X 40"
12	DWM205	MALE COUPLER
13	DWM233	3/8" ADAPTER UNION

NOTE: * MEANS NOT SHOWN

FIGURE 10

9' MERGER WIRING & LIGHTS

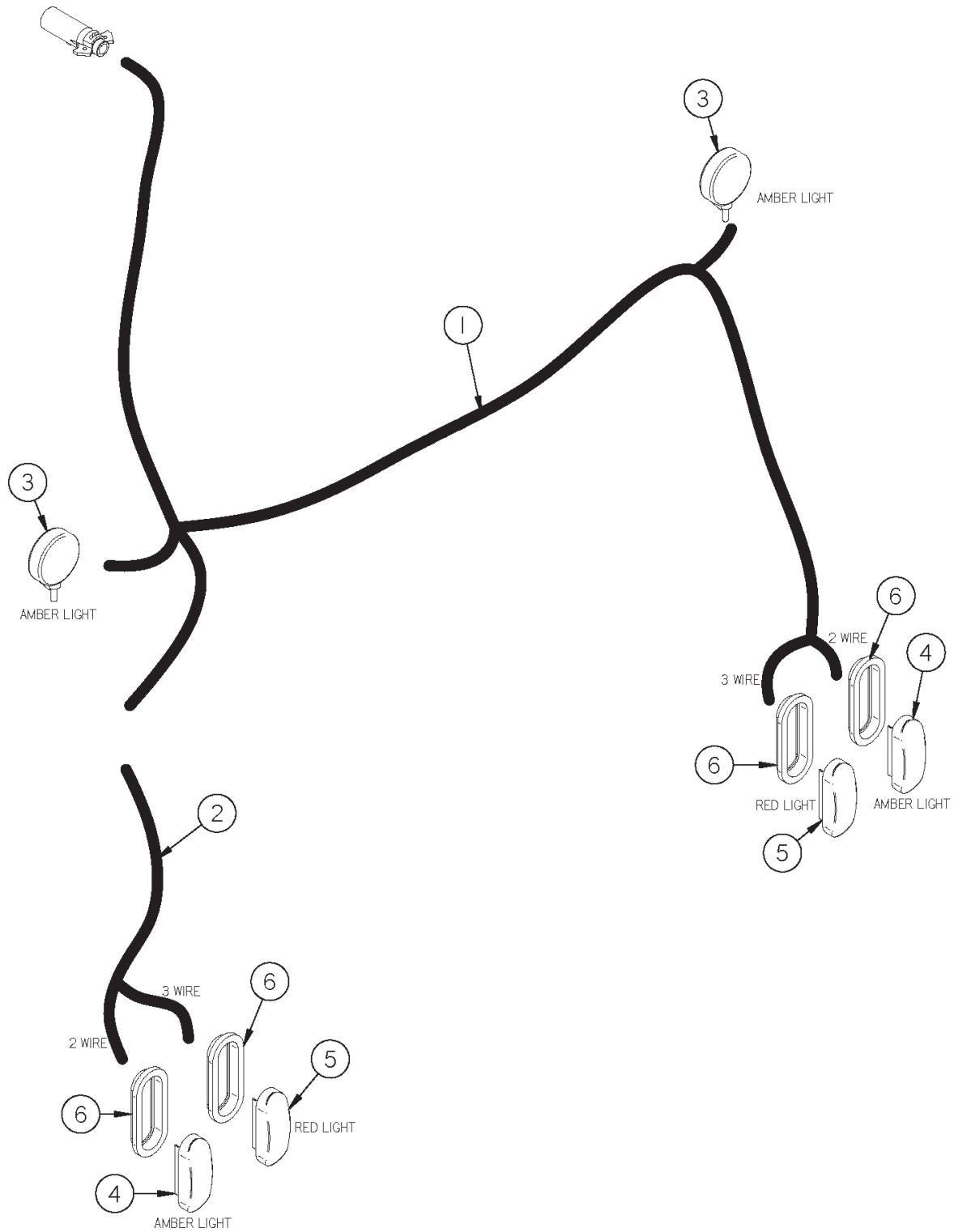

FIGURE 10

9' MERGER WIRING & LIGHTS

<u>ITEM</u>	<u>PART #</u>	<u>DESCRIPTION</u>
1	WM364	LIGHT HARNESS (RIGHT)
2	WM366	LIGHT HARNESS (LEFT)
3	DWM129	YELLOW HAZARD THIN LIGHT 2-WAY
4	S309	YELLOW HAZARD LIGHT
5	S310	RED TAIL LIGHT
6	S308	RUBBER LIGHT MOUNT

FIGURE 11

12' MERGER WIRING

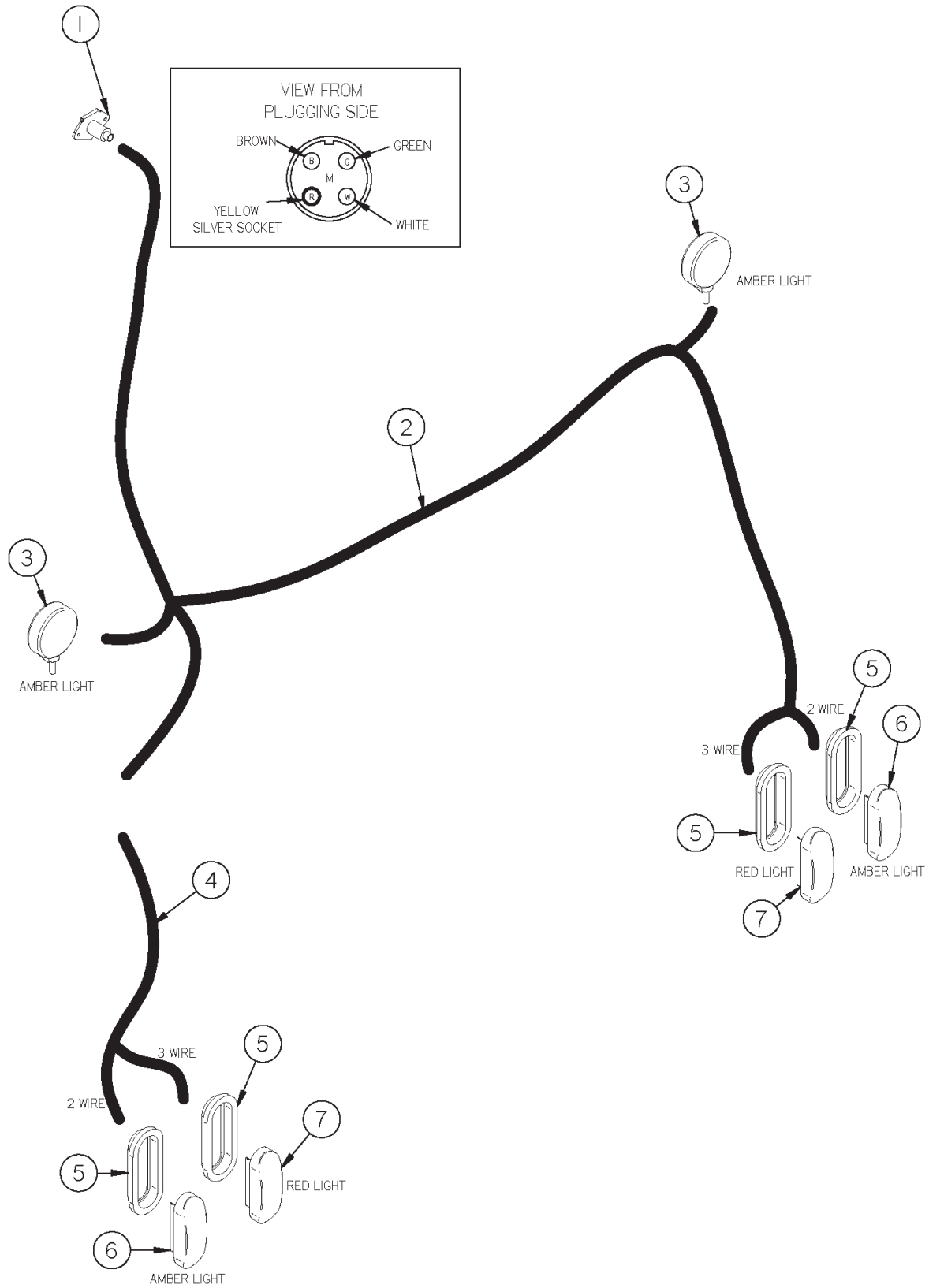

FIGURE 11

12' MERGER WIRING

<u>ITEM</u>	<u>PART#</u>	<u>DESCRIPTION</u>
1	SWM46	PLUG IN
2	WM365	LIGHT HARNESS (RIGHT)
3	DWM129	AMBER LIGHT (YELLOW HAZARD)
4	WM366	LIGHT HARNESS (LEFT)
5	S308	RUBBER LIGHT MOUNT
6	DWM131	AMBER LIGHT
7	S310	RED LIGHT
*	WM331	COMPLETE LIGHT HARNESS

NOTE: * MEANS NOT SHOWN

FIGURE 12
9'/12' MERGER CONTROL BOX

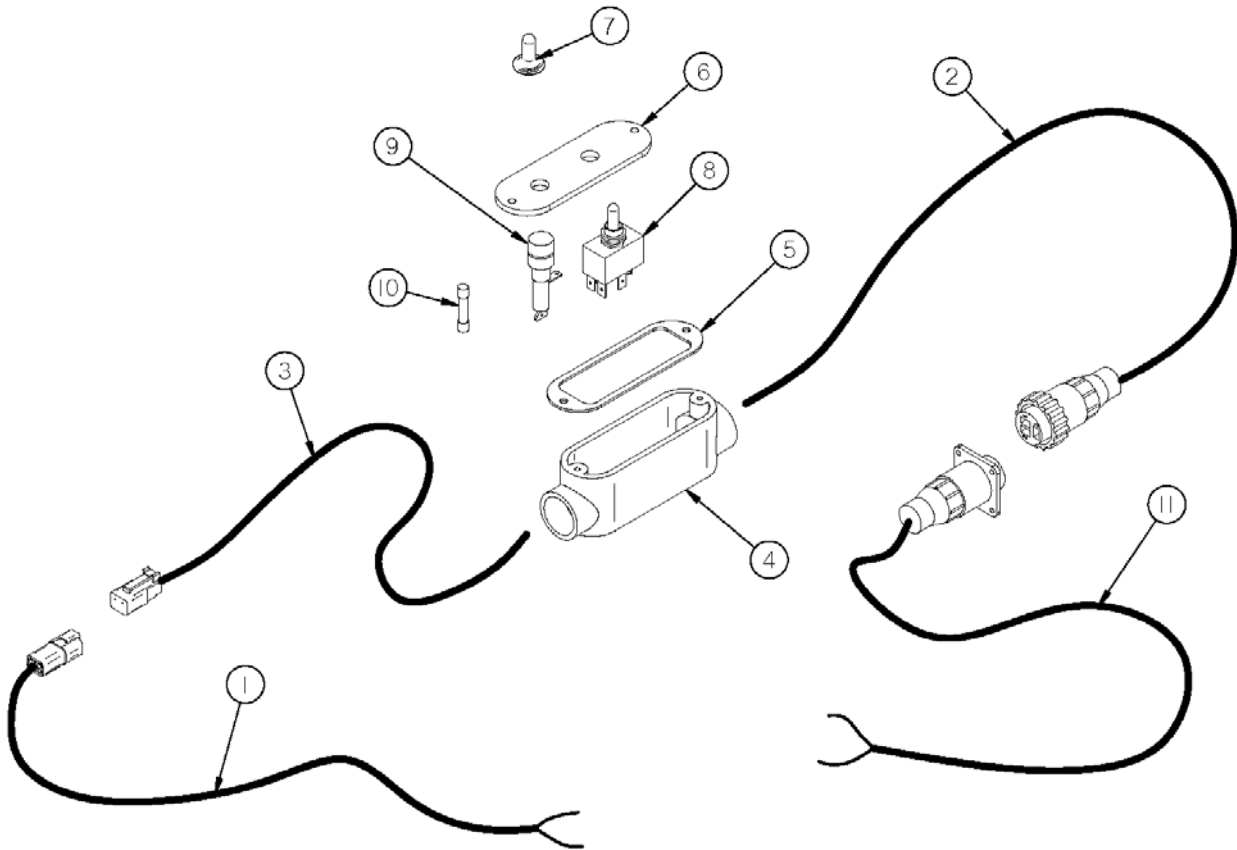

FIGURE 12

9'/12' MERGER CONTROL BOX

<u>ITEM</u>	<u>PART #</u>	<u>DESCRIPTION</u>
1	WM108	MERGER POWER SUPPLY CORD W/ ENDS
2	16SV271	CONTROL BOX POWER SUPPLY W/ PLUG IN SLOTS
3	16SV270	TRACTOR POWER SUPPLY W/ PINS
4	16SV316	CONTROL BOX
5	16SV317	CONTROL BOX GASKET
6	16SV318	CONTROL BOX COVER
7	16SV235	SWITCH BOOT
8	WM109	POLE / PICKUP SWITCH
9	16SV231	FUSE FOLDER
10	16SV232	FUSE
11	16SV269	TRACTOR CONTROL CORD
12	5108	DECAL
*	WM110	CONTROL BOX COMPLETE

NOTE: * MEANS NOT SHOWN

FIGURE 13

9'/12' MERGER PICKUP HYDRAULIC CYLINDER 2 X 8

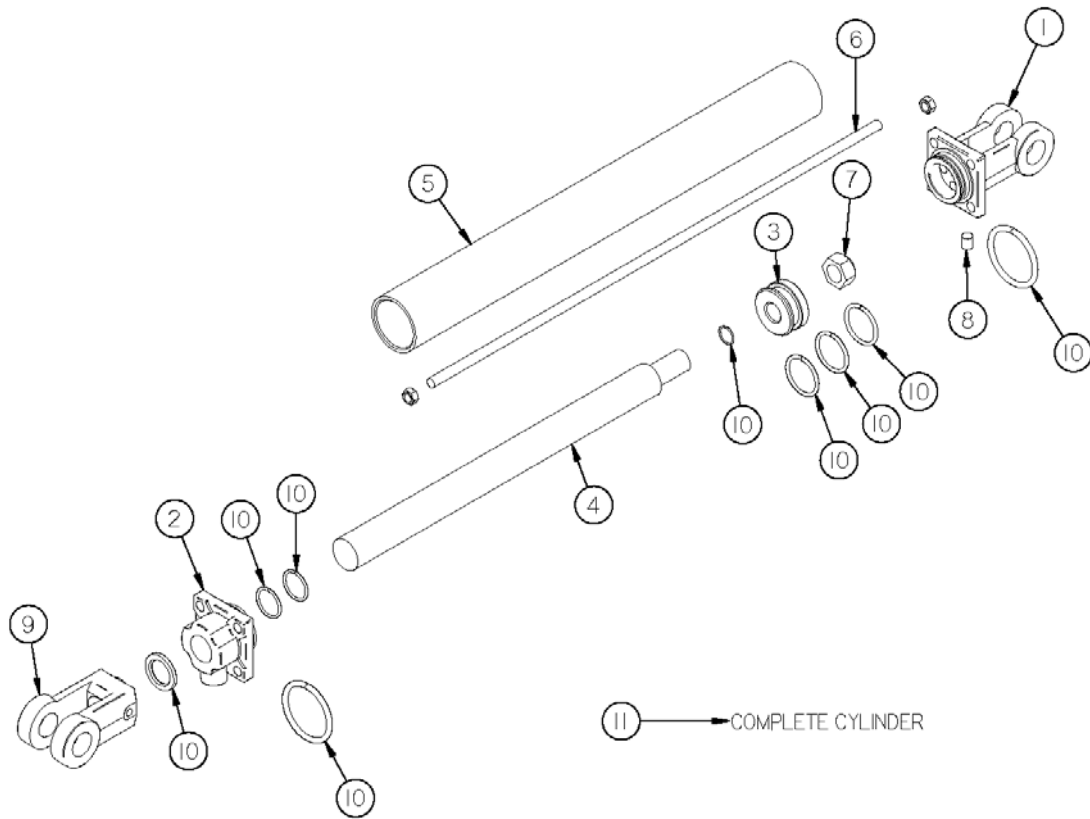

ITEM	PART #	DESCRIPTION
1	23N142A	CLEVIS
2	56174	ROD CAP
3	56180	PISTON
4	T184A	ROD
5	BFR68	CYLINDER TUBE
6	T186	TIE ROD
7	23N148	PISTON NUT
8	23N149	PLUG
9	23N150A	ROD CLEVIS
10	56187	SEAL KIT
11	55999	COMPLETE CYLINDER

FIGURE 14

9'12' MERGER POLE HYDRAULIC CYLINDER 16"

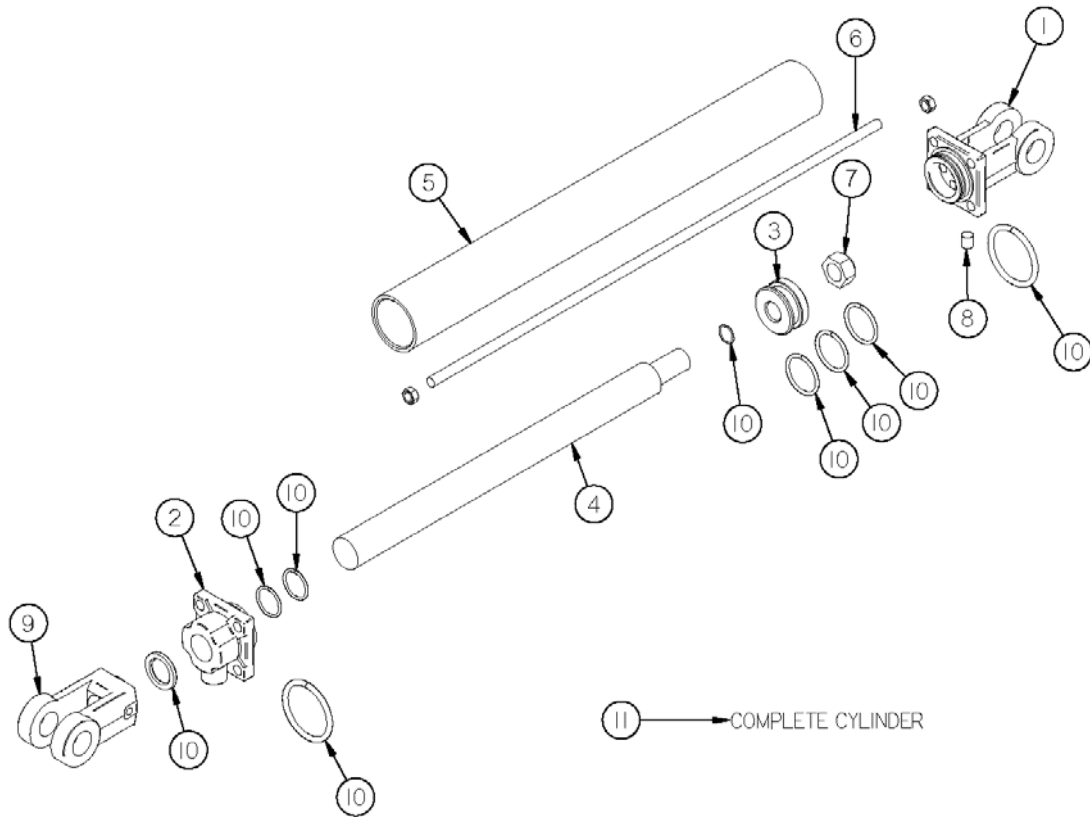

ITEM	PART #	DESCRIPTION
1	23N142A	CLEVIS
2	23N143A	ROD CAP
3	23N144	PISTON
4	23N145A	ROD
5	23N146	CYLINDER TUBE
6	23N147	TIE ROD
7	23N148	PISTON NUT
8	23N149	PLUG
9	23N150A	ROD CLEVIS
10	23N151	SEAL KIT
11	12V116A	COMPLETE CYLINDER

FIGURE 15
9'/12' MERGER OPTIONAL EXTENSION
HYDRAULIC CYLINDER

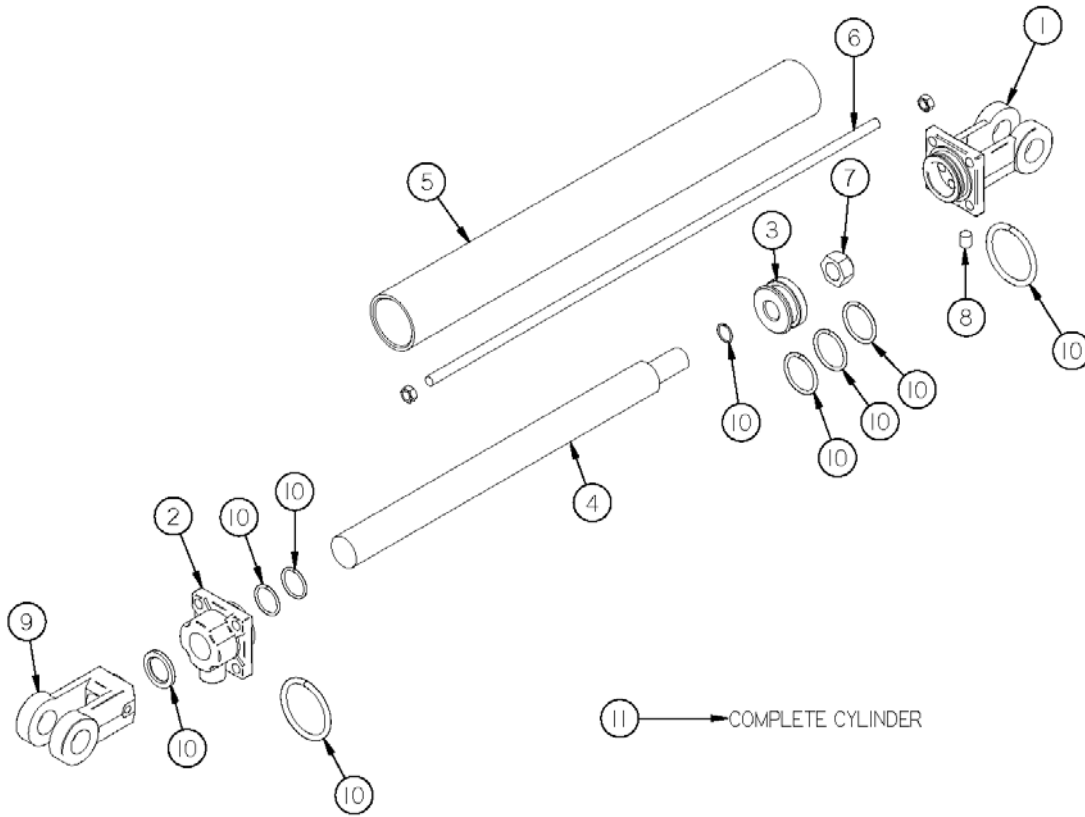

<u>ITEM</u>	<u>PART #</u>	<u>DESCRIPTION</u>
1	23N142A	CLEVIS
2	56174	ROD CAP
3	56180	PISTON
4	23N145A	ROD
5	23N146	CYLINDER TUBE
6	23N147	TIE ROD
7	23N148	PISTON NUT
8	23N149	PLUG
9	23N150A	ROD CLEVIS
10	56187	SEAL KIT
11	56015	HYDRAULIC CYLINDER

FIGURE 16
OPTIONAL WINDROW INVERTER

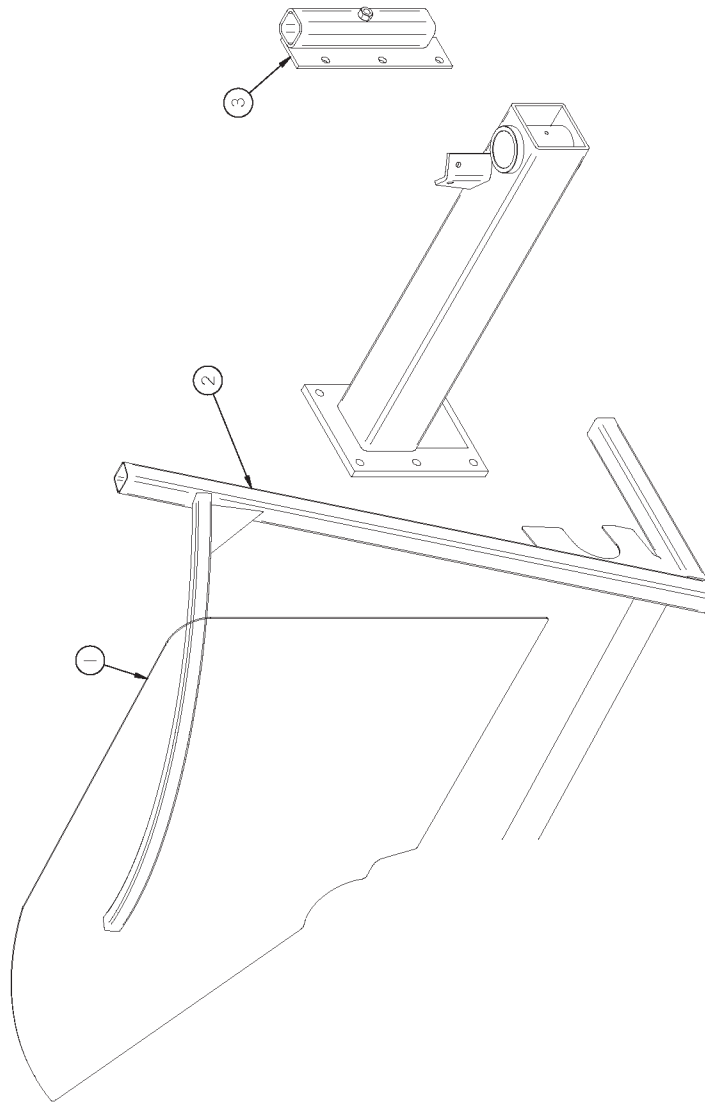

<u>ITEM</u>	<u>PART #</u>		<u>DESCRIPTION</u>
	<u>9' HEAD</u>	<u>12' HEAD</u>	
1	SWM50	"	WINDROW INVERTER POLY
2	SWM51	"	WINDROW INVERTER FRAME
3	SWM52	"	STORAGE MOUNT

NOTE: " MEANS SAME AS PREVIOUS

NOTE: STORAGE MOUNT BOLTS ONTO SWM3 CASTER MOUNT - ITEM #4 (FIG 1)

FIGURE 17

9'/12' MERGER OPTIONAL CROSS CONVEYOR STOP KIT

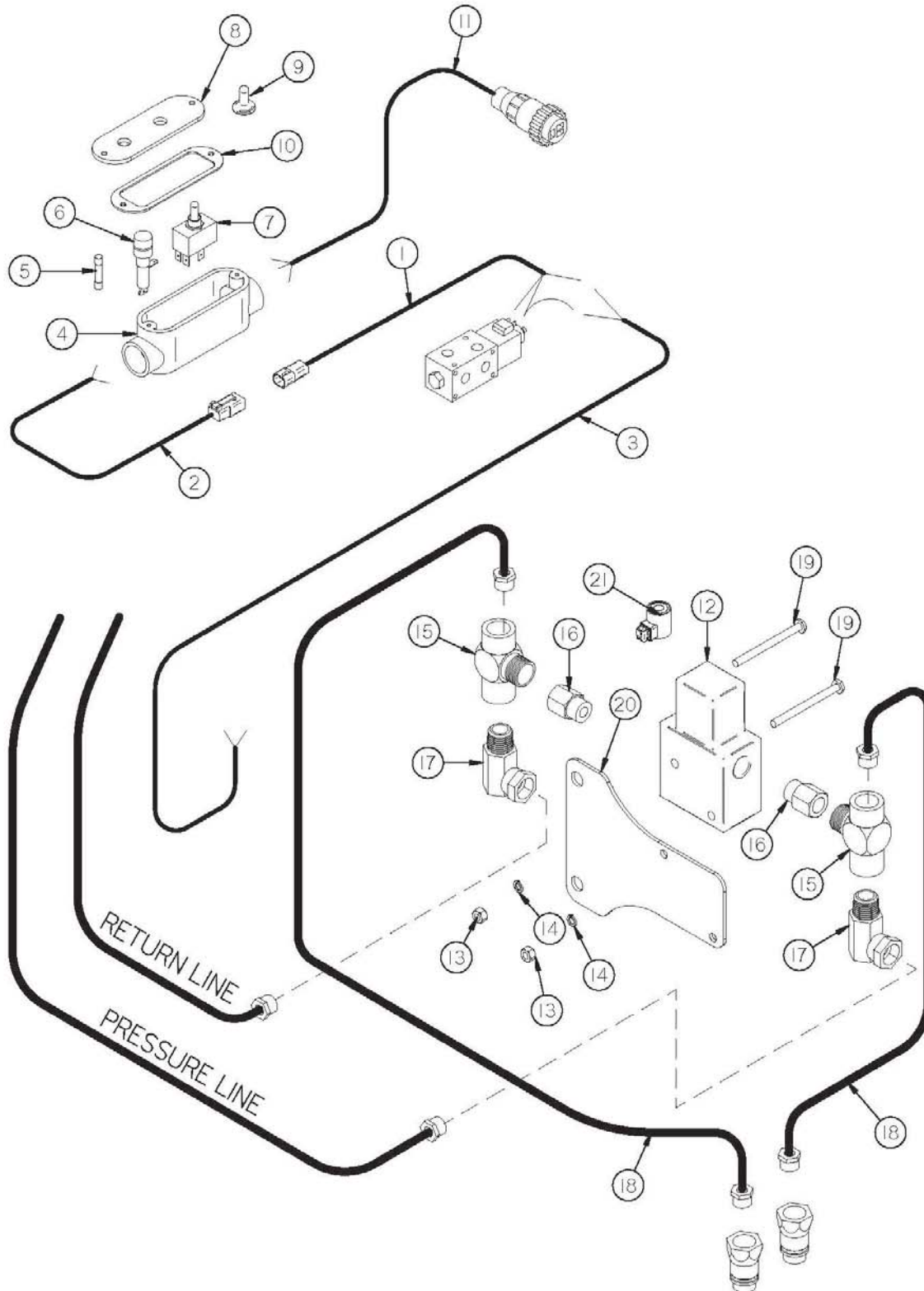

FIGURE 17

9'/12' MERGER OPTIONAL CROSS CONVEYOR STOP KIT

<u>PART #</u>			
<u>ITEM</u>	<u>9' HEAD</u>	<u>12' HEAD</u>	<u>DESCRIPTION</u>
1	WM283	"	POLE CORD (18')
2	WM284	"	TRACTOR SUPPLY CORD (5'6")
3	WM327	"	SOLENOID CORD (23' 4")
4	16SV316	"	CONTROL BOX
5	16SV232	"	FUSE
6	16SV231	"	FUSE HOLDER
7	8614	"	SWITCH (SPDT)
8	16SV318	"	CONTROL BOX COVER
9	16SV235	"	SWITCH BOOT
10	16SV317	"	CONTROL BOX GASKET
11	16SV271	"	CONTROL BOX POWER SUPPLY W/ PLUG IN SLOTS
*	WM345		COMPLETE CONTROL BOX (INCLUDES ITEMS # 2, 4-12)
12	WM293	"	VALVE
13	YNHX08005	"	1/4"-20 NUT
14	YWLO08005	"	1/4" LOCK WASHER
15	WM139	"	1/2" TEE
16	WM289	"	7/8" O-RING TO 1/2" NPT BUSHING
17	WM175	"	ADAPTER, UNION, 1/2" NPT MALE X 1/2" NPT SWIVEL FEMALE, 90 DEGREE
18	DWM101	"	1/2" X 49" - 1/2" MPX & 1/2"MP HOSE
19	YBHH08055	"	1/4" X 2-1/2" GR. 5 BOLT
20	WM333	"	VALVE BRACKET
21	8739	"	COIL FOR WM293 VALVE

NOTE: " MEANS SAME AS PREVIOUS

FIGURE 18

9'/12' MERGER OPTIONAL WET KIT

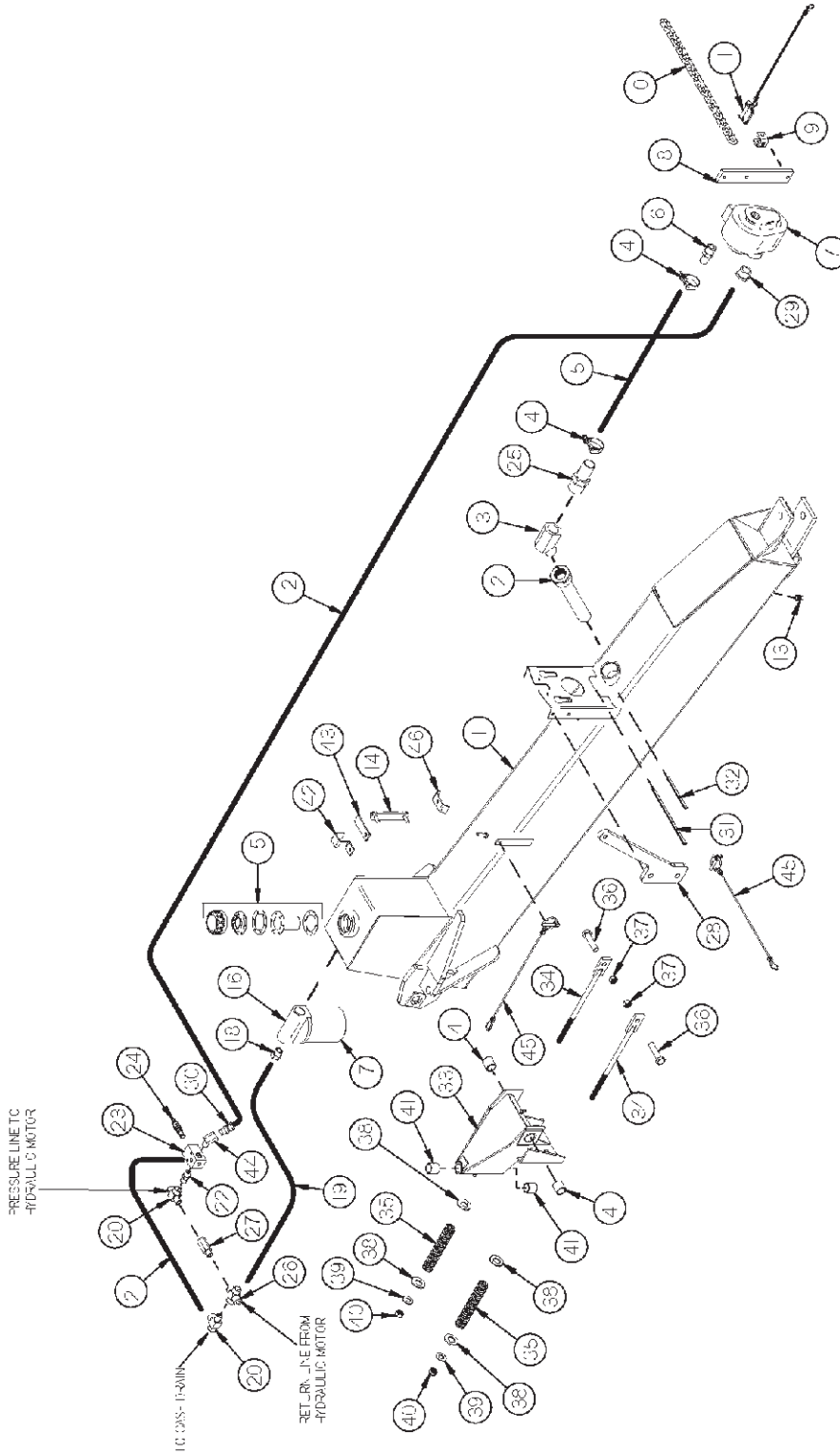

FIGURE 18

9'/12' MERGER OPTIONAL WET KIT

PART

<u>ITEM</u>	<u>9' HEAD</u>	<u>12' HEAD</u>	<u>DESCRIPTION</u>
1	HSW15	"	POLE TANK
2	HSW13	"	SUCTION PIPE
3	DWM242	"	STREET ELBOW 45°
4	DWM138	"	HOSE CLAMP
5	HSW3	"	SUCTION HOSE 1-1/4" X 46"
6	HSW9	"	HOSE BARB 1-5/16-12 TO 1-1/4 TUBE
7	HSW16	"	PTO PUMP
8	WM168	"	TORQUE ARM
9	HSW5	"	CHAIN YOKE
10	BFR111	"	CHAIN
11	HSW20	"	LANYARD, PUMP CHAIN
12	HSW6	"	HYDRAULIC HOSE 3/4 X 122 #12 SAE x 1/2 MP
13	DWM159	"	DRAIN PLUG
14	DWM204	"	OIL LEVEL GAUGE
15	DWM81	"	FILLER STRAINER CAP
16	LW119	"	FILTER BASE
17	LW289	"	FILTER
18	LW99	"	BUSHING 3/4" TO 1/2"
19	16SV143	"	HYDRAULIC HOSE 1/2 x 19" 1/2 MP - 1/2 MPX
20	LW96	"	SERVICE TEE 1/2"
21	S395	"	HYDRAULIC HOSE 1/2 x 10.5" 1/2 MP - 1/2" 90°
22	WM141	"	MPX
23	56350		NIPPLE 1/2"
24	56349		RELIEF VALVE MANIFOLD
			RELIEF VALVE CARTRIDGE

NOTE: " MEANS SAME AS PREVIOUS

FIGURE 18

9'/12' MERGER OPTIONAL WET KIT

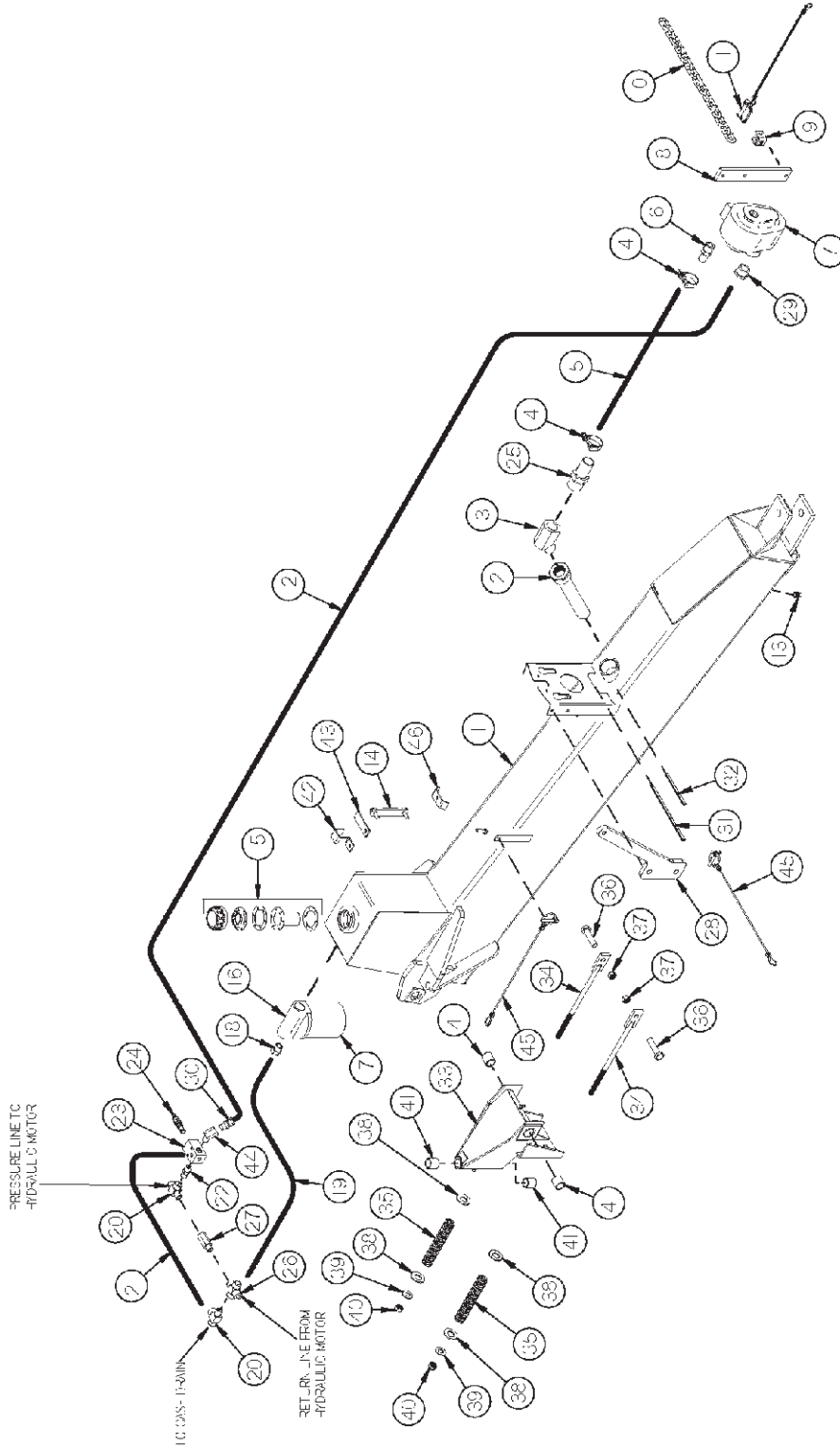

FIGURE 18

9'/12' MERGER OPTIONAL WET KIT

PART

<u>ITEM</u>	<u>9' HEAD</u>	<u>12' HEAD</u>	<u>DESCRIPTION</u>
*	56348	"	RELIEF VALVE (ITEM #'S 23 & 24)
25	DWM143	"	HOSE BARB
26	JB83	"	1/2" CROSS
27	DF18	"	1/2" CHECK VALVE
28	HSW8	"	PUMP HOLDER
29	HSW10	"	PORT BUSHING 1-5/16-12 TO 1-1/16-12
30	MA12	"	1/2" MALE ADAPTER UNION
31	HSW11	"	HOLE EDGING
32	HSW12	"	SLOT EDGING
33	HSW14	"	SPRING ASSIST PIVOT
34	RG10	"	SPRING ADJUST ROD
35	T148	"	SPRING
36	YBHH20020	"	BOLT, 5/8" X 1-3/4" GR. 5
37	YNTL20005	"	HEX NUT, TOP LOCK, 5/8"-11
38	RG9	"	SPRING RETAINER
39	YWFL20005	"	WASHER, FLAT, 5/8" USS
40	YNNY20005	"	HEX NUT, NYLON LOCKNUT, 5/8"-11
41	RG11	"	1" ID X 1-1/4" OD X 2" BUSHING
42	HE15	"	HOSE CLAMP
43	HSW17	"	HOSE CLAMP BASE
44	LW187	"	STREET ELBOW 45°
45	WM377	"	LANYARD, CROP ROLLER
46	HE42	"	HOSE HOLDER

NOTE: " MEANS SAME AS PREVIOUS

FIGURE 19

EXTENSION SHUTOFF

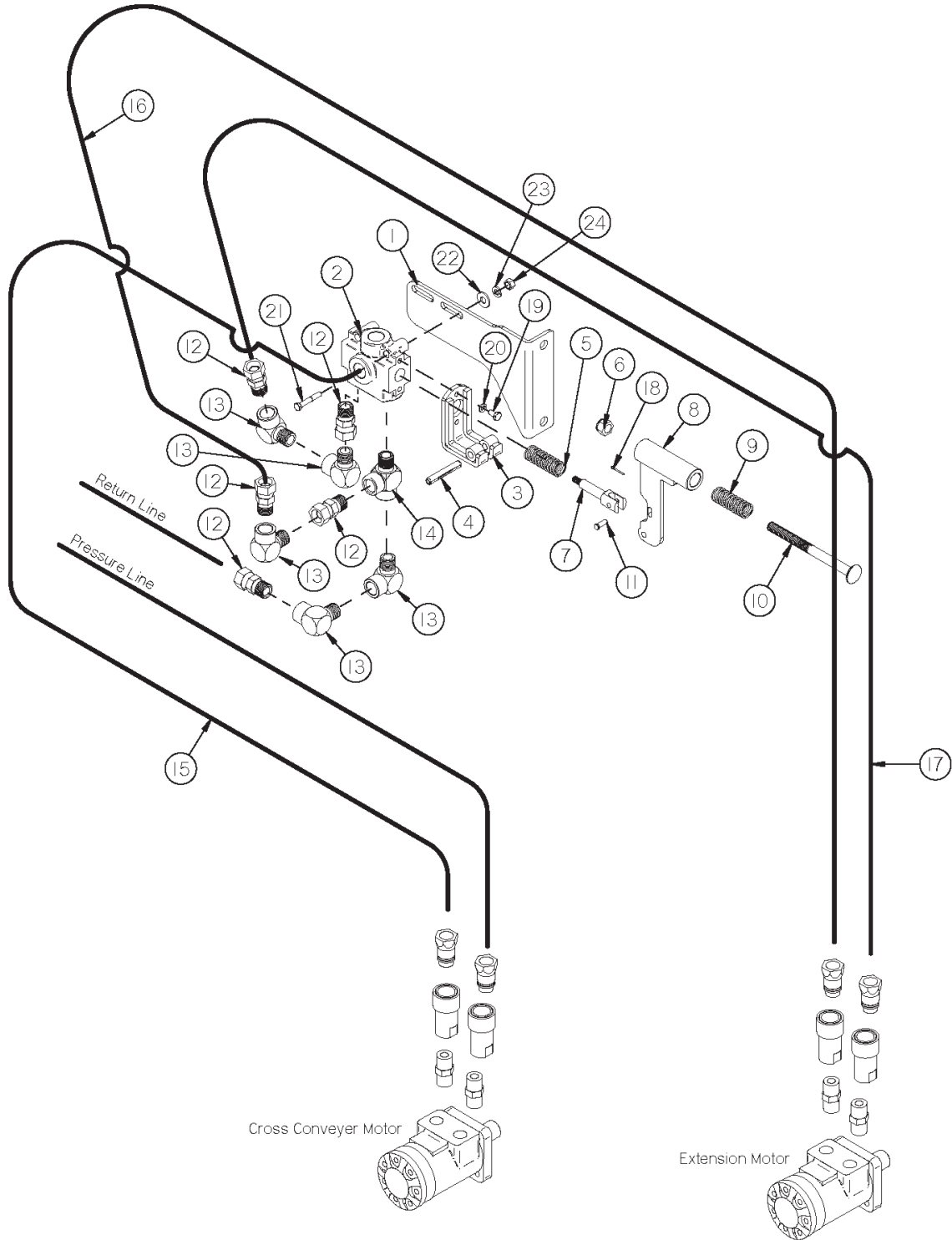

FIGURE 19

EXTENSION SHUTOFF

PART #			
ITEM	9' HEAD	12' HEAD	DESCRIPTION
1	WM335	“	SHUT-OFF BRACKET
2	16SV133	“	SELECTOR VALVE
3	WM324	“	SHUT-OFF LEVER BRACKET
4	YPEX12020	“	EXPANSION PIN, 3/8" X 2"
5	T241	“	SPRING
6	YNNJ16005	“	HEX NUT, NYLON JAM NUT, 1/2"
7	WM336	“	SPRING PIN
8	WM334	“	SPRING GUIDE LEVER
9	23N211	“	SPRING
10	WM337	“	SPRING GUIDE BOLT
11	YPCV08005	“	CLEVIS PIN, 1/4" X 1"
12	MA12	“	1/2" MALE ADAPTER UNION
13	HE58	“	STREET ELBOW (5502-8-8)
14	LW96	“	SERVICE TEE (5602-8)
15	WM263	“	HYDRAULIC HOSE
16	WM264	“	HYDRAULIC HOSE
17	DWM101	“	HYDRAULIC HOSE
18	YPCT02005	“	COTTER PIN, 1/16" X 1/2"
19	YBHH08015	“	BOLT, 1/4" X 1/2" GR. 5
20	YWLO08005	“	WASHER, LOCK, 1/4"
21	YBHH10070	“	BOLT, 5/16"-18 X 2" GR. 5
22	YWFL10005	“	WASHER, FLAT, 5/16" USS
23	YWLO10005	“	WASHER, LOCK, 5/16"
24	YNHX10005	“	HEX NUT, 5/16"

NOTE: “ MEANS SAME AS PREVIOUS

H&S MFG. CO.

products approved

for the

FEMA

SEAL OF QUALITY

